

Accident procedure:

Any crew which has the red “SOS” sign displayed to them, or which sees a vehicle which has suffered an accident and the “OK” sign is not shown, shall immediately and without exception stop to render assistance. All following vehicles shall also stop.

In the case of an accident where urgent medical attention is required, the following applies:

- the SOS switch on the emergency console (tracking system) must be activated as soon as possible (if applicable);
- when possible the red “SOS” sign should immediately be displayed to the following vehicles and to any helicopter attempting to assist;
- as soon as possible, the red triangle should be placed in a conspicuous position on the same side of the road as the vehicle by a member of the crew at least 50 metres before the vehicle’s position, in order to warn following crews. (Each competing vehicle shall carry a red “SOS” sign and on the reverse a green “OK” sign measuring at least 42 cm x 29.7 cm (A3).)











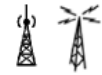





































EMERGENCY CALL
+966 55 88 48944

TRACKS	
	Tarmac road
	Track Piste
	Off track (HP)
	Low visible track / traces
P	Track Piste
PP	Principal track / piste
RO	Road
P//	Paralell track/piste
HP	Off track Sight driving!
HP	Off track forbidden
FPP	Follow principal track/piste
FRO	Follow road
SA	Sandy
GV	Gravel
SAFETY	
!	Danger Level 1
!!	Danger Level 2
!!!	Danger Level 3
	Global danger in the note
	Start Speed limit
	Finish Speed limit

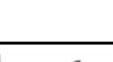
	STOP
	Important
25,25	Red line under km = danger 2 in the note
WAYPOINTS	
	Masked WP
	Control WP
	Security WP
	Navigation WP
	Precise WP
	Visible WP
	Eclipse WP
1	Waypoint number
ZONES	
	Start Selective Section
	Arrival Selective Section
	Check point
	Start/Finish Neutralization
	Start Neutralization with speed limit
	Start/Finish Transfer
	Start Transfer with speed limit
T:25	Neut./Transfer max. time allowed
	Waiting for restart

	Stop for restart
	Fuel zone with authorized cat.
	Time control
	Assistance Service
	Tyre marking zone
	End zone
ON TRACK	
	Bump
	Dip hole
	Compression
	Ditch
	Summit
	Above bridge
	Under bridge
	Step up
	Step down
	Up hill Down hill
	Cut danger
	Right of Left over crest
	Fence gate
	Fence with cattle gate
	Wall gate

	Wading / water cross
	Concrete pass
CAPS	
180	Exit cap
180A	Average cap
180C	Calculated cap (only HP)
OBLIC	Cap that turns
SYMBOLS	
	Fence
	Barbed fence
	Rail road
	Hole
	Collapse, ditch, ravine, etc.
	Ruts
	Twisty / sinuous
	Bumpy / broken
	Bumpy
	Lateral inclination
	Post
	Electric pole
	Electric line
	High voltage tower

	Antenna		Monument	DUNES / SAND			More / less visible
	Well		Animals individual		Sandy plain	ALT	Alternance
	Tanks		Animals		Big bowl "cuvette"	/	During
	Barrels		Cairn		Sand spit	IN	In / into
	Notable elements		Rocks		Dune	ET	And / Next
	Tires		Mountain		Broken dune	A	At
	Sign posts		Tree		Dunes	CX	Stone / stony
	Restricted / protected area		Palm tree	DN	Dune	E3	Narrow
	Buildings / houses		Camel grass	DNX	Many dunes	Q^T	Quit / leave
	Church / mosque		Vegetation	DNT	Small dune "dunette"	TJS	Always
SYMBOLS			Slope	L1 L2 L3	Dunes difficulty level	NBX	Many
	Ruine / abandoned		Small wadi	ABBREVIATIONS		IMP	Imperative
	Fort / castle		Large wadi	VG	Vegetation	EFF	Collapsed
	Cemetery		Sandy wadi	L/R	Left and Right	ORN	Ruts
	Village		River (water)	R/L	Right and Left	BAD	Bad
	Bivouac		Lake / puddle	onL	On left	RP	Rejoin
	Tunnel		Plain / chott	onR	on right	BTW	Between
	Pipeline		Towards / direction	kpL	Keep to the left	MODIF	Modification from Opening Car
	Wall		Road works	kpR	Keep to the right	NEW NOTE	New note from Opening Car
	Native / Local camp		Reset / recal trip	kpS	Keep straight	BIG	Written as text (English)
	Petrol station & type of fuel		Distance	-V	Less visible	SMALL	
						FOLLOW	

Total km	Name & Number	Total km	Name & Number
109,06	TC1 0	113,11	WPM 42
0,00	DSS 1 (ASC Start)	114,34	WPM 43
1,60	WPM 1.1	116,35	DZ 44
3,47	WPM 1.2	116,97	!!!
5,59	WPM 2	117,21	FZ 45
15,27	WPM 3	119,39	WPM 46
17,34	WPM 4 (ASC Finish)	119,82	WPM 47
17,60	DZ 5	122,74	DZ 48
18,60	FZ 6	124,71	FZ 49
19,49	WPM 7	125,45	WPM 50
20,84	WPM 8	129,51	WPM 51
25,29	WPM 9	130,66	WPM 51.1
27,92	WPM 10	130,99	WPM 52
31,56	WPM 10.1	131,88	WPM 52.1
33,05	WPM 11	133,16	WPM 53
35,03	WPM 12	134,36	WPM 54
38,16	WPM 13	135,62	WPM 55
40,45	WPM 14	137,95	WPM 56
44,86	WPM 15	139,34	WPM 57
46,63	WPM 16	140,21	WPM 58
47,92	WPM 17	141,56	ASS 59
50,30	WPM 18	0,00	STOP 60
53,37	WPM 19		
55,01	WPM 19.1		
60,23	WPM 20		
63,51	WPM 21		
65,05	WPM 22		
68,49	WPM 23		
70,14	WPM 24		
70,70	ASC Start		
71,98	WPM 25		
75,73	WPM 26		
78,03	WPM 27		
82,58	WPM 28		
85,99	WPM 29		
88,47	WPM 30		
94,72	WPM 31 (ASC Finish)		
97,25	WPM 32		
98,60	WPM 33		
98,98	WPM 34		
100,36	WPM 35		
102,24	WPM 36		
104,23	WPM 37		
105,74	WPM 38		
106,49	WPM 39		
108,69	WPM 40		
111,01	WPM 41		

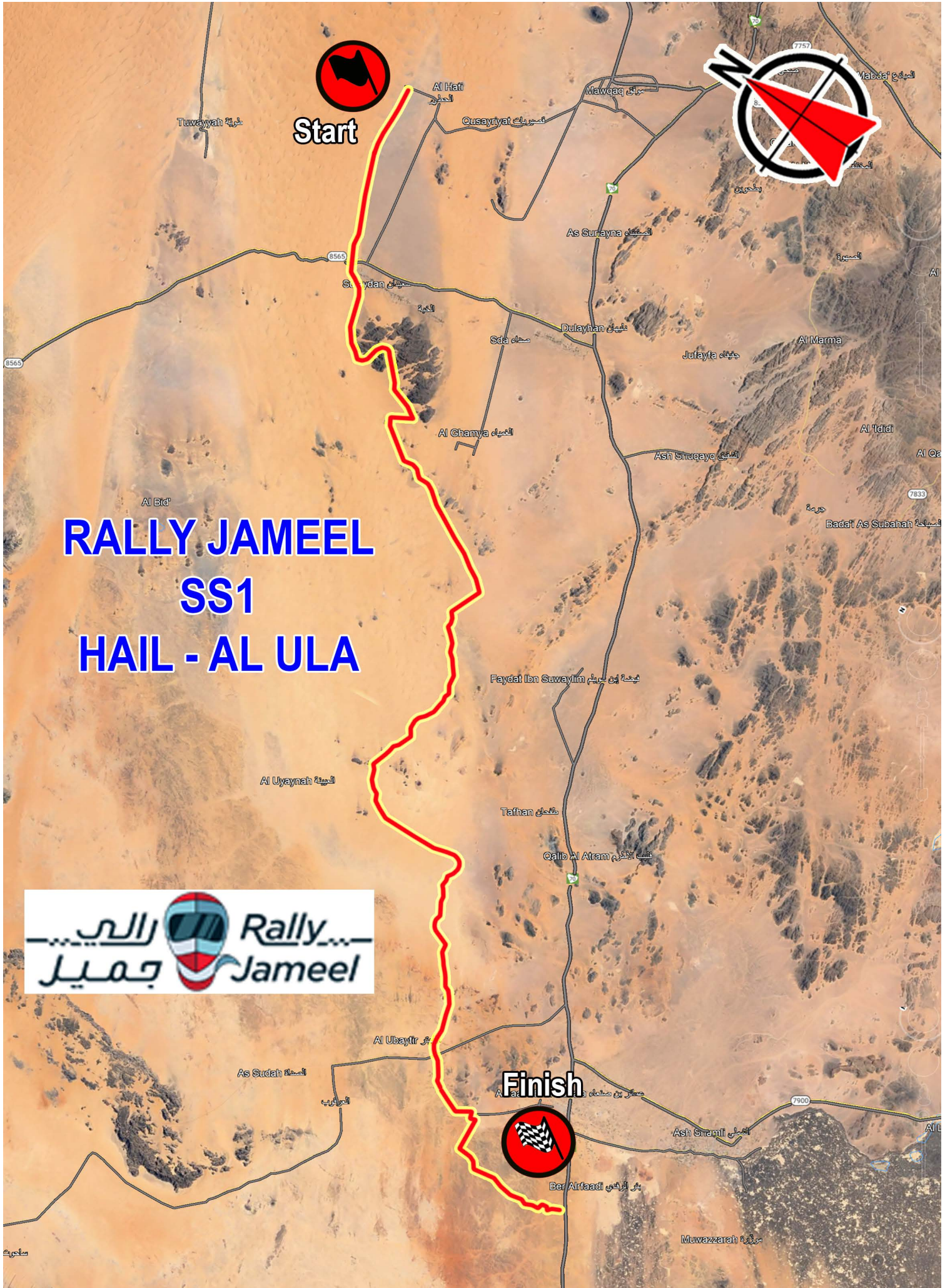



Start

Finish

RALLY JAMEEL
SS1
HAIL - AL ULA

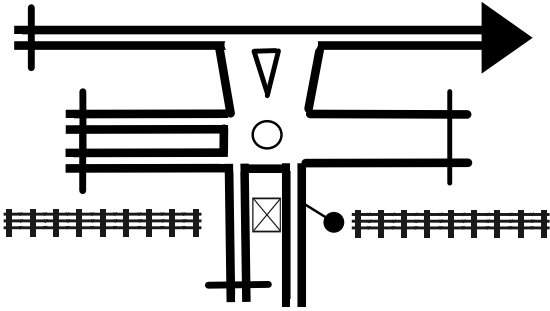

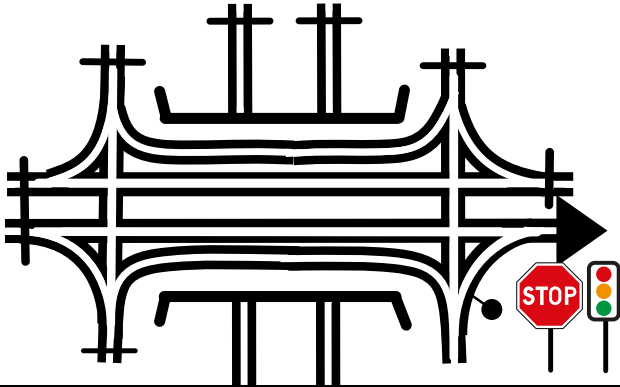
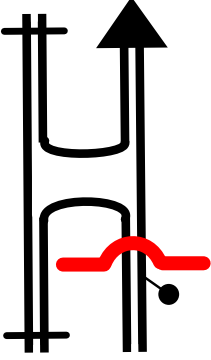
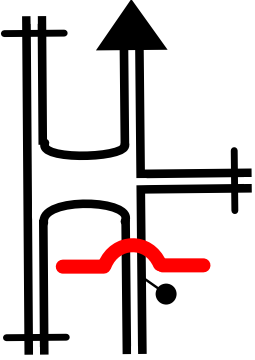
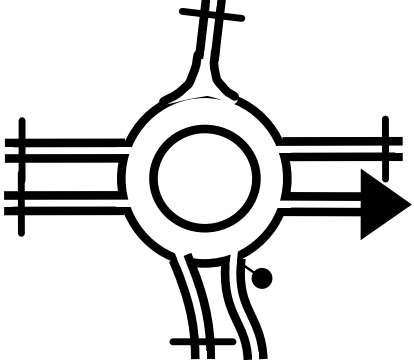

6	<p>RALLY JAMEEL 2024 / DAY 1 Tuesday HAIL SERVICE OUT - ROAD SECTION A / 109,06 km</p>	<p>Km : 109,06</p>
<p>0,00</p>		<p> TC 0</p> <p>HAIL Service Out</p> <p>N27°39.167 E41°43.529</p>
<p>0,00</p>		<p><u>DIRECTION</u> AL LQUTA</p>
<p>0,39</p>		
<p>2,09</p>		
<p>1,70</p>		<p><u>DIRECTION</u> QANA JUBBAH</p>
<p>1,34</p>		
<p>7,51</p>		
<p>4,08</p>		

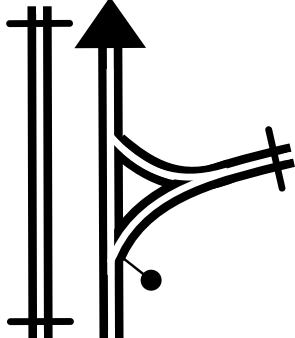
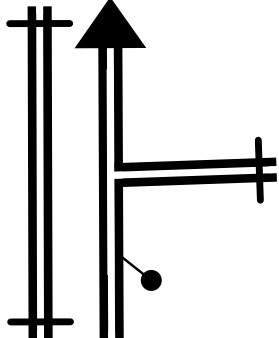
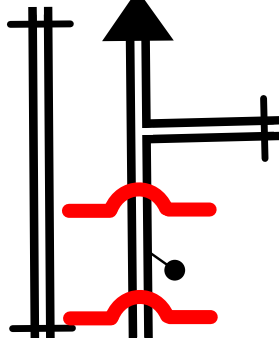
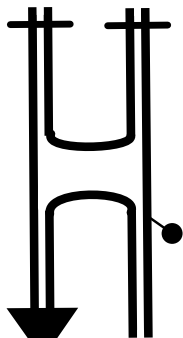
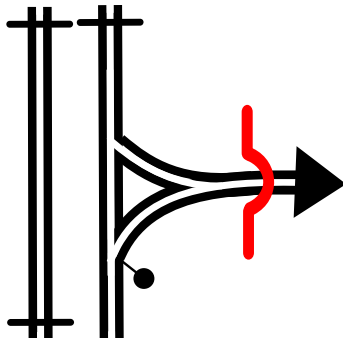
Next 7,59

7	RALLY JAMEEL 2024 / DAY 1 Tuesday HAIL SERVICE OUT - ROAD SECTION A / 109,06 km	Km : 93,96
<p data-bbox="95 212 414 347">15,10</p> <p data-bbox="71 414 263 515">7,59</p>		<p data-bbox="1189 190 1532 235"><i>WRONG DIRECTION</i></p> <p data-bbox="1236 257 1484 324">OBAIRAH</p>
<p data-bbox="95 604 406 739">22,41</p> <p data-bbox="71 806 255 907">7,31</p>		<p data-bbox="1189 582 1532 627"><i>WRONG DIRECTION</i></p> <p data-bbox="1252 649 1468 716">Al Sufon</p>
<p data-bbox="95 996 422 1131">23,76</p> <p data-bbox="71 1198 263 1299">1,35</p>		<p data-bbox="1220 1019 1500 1064">CHECK POINT</p>
<p data-bbox="95 1388 422 1523">26,39</p> <p data-bbox="71 1590 263 1691">2,63</p>		<p data-bbox="1260 1366 1460 1411"><i>DIRECTION</i></p> <p data-bbox="1228 1433 1500 1478">AL HUFAIR</p> <p data-bbox="1292 1500 1412 1545">HAIL</p> <p data-bbox="1340 1590 1372 1680">!</p>
<p data-bbox="95 1780 422 1915">26,74</p> <p data-bbox="71 1982 263 2083">0,35</p>		<p data-bbox="1300 1780 1428 1870">PP</p>

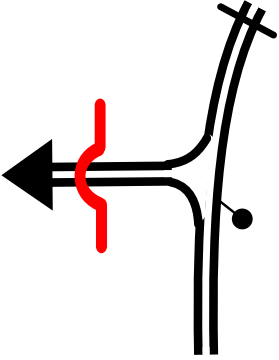
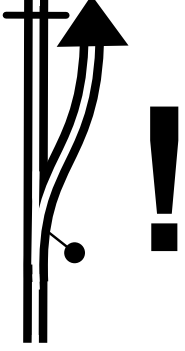
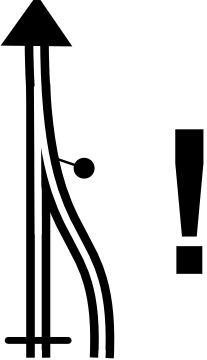
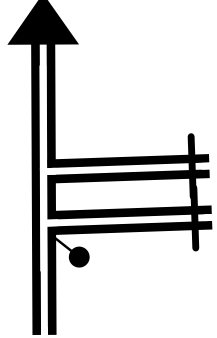
Next 27,29

8	RALLY JAMEEL 2024 / DAY 1 Tuesday HAIL SERVICE OUT - ROAD SECTION A / 109,06 km	Km : 55,03
<p data-bbox="92 210 421 353">54,03</p> <p data-bbox="44 412 293 524">27,29</p>		<p data-bbox="1257 309 1289 412">!</p>
<p data-bbox="92 600 421 743">59,39</p> <p data-bbox="76 801 277 913">5,36</p>		
<p data-bbox="92 990 421 1133">60,93</p> <p data-bbox="76 1191 277 1303">1,54</p>		
<p data-bbox="92 1379 421 1523">74,95</p> <p data-bbox="51 1581 300 1693">14,02</p>		<p data-bbox="1193 1361 1535 1496"><i>WRONG DIRECTION</i> ROADH ALABD</p>
<p data-bbox="92 1769 421 1912">81,93</p> <p data-bbox="76 1971 277 2083">6,98</p>		

Next 2,19

9

RALLY JAMEEL 2024 / DAY 1 Tuesday
HAIL SERVICE OUT - ROAD SECTION A / 109,06 km

Km : 24,94

84,12

2,19

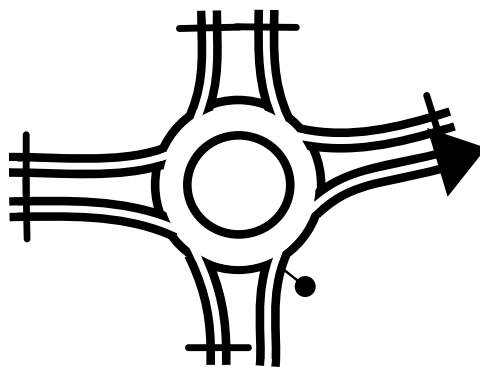

84,77

0,65

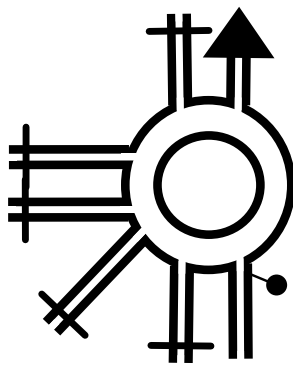

86,76

1,99

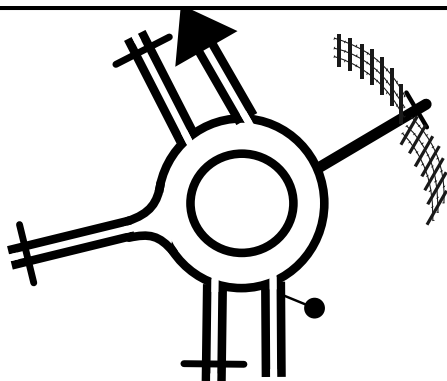

88,28

1,52

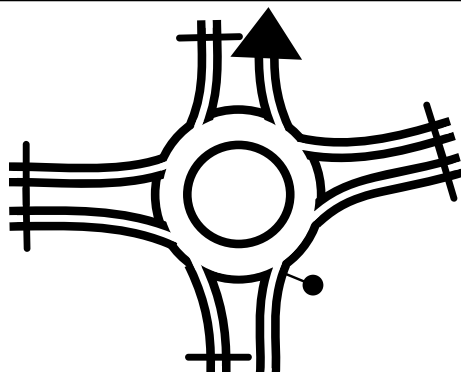

94,61

6,33

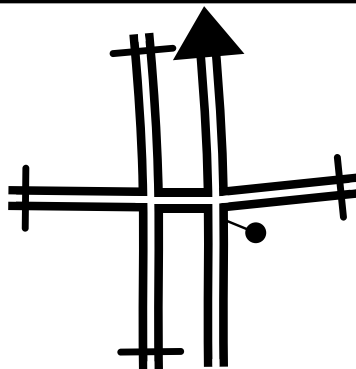

Next 1,78

10

RALLY JAMEEL 2024 / DAY 1 Tuesday
HAIL SERVICE OUT - ROAD SECTION A / 109,06 km

Km : 12,67

96,39

1,78

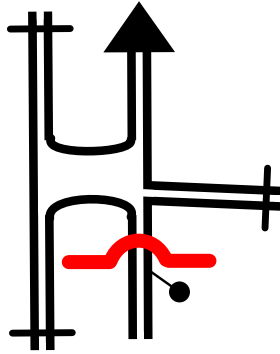

97,05

0,66

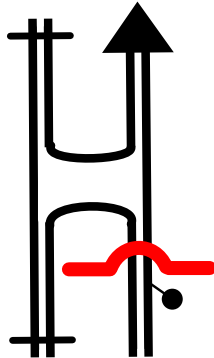

102,30

5,25

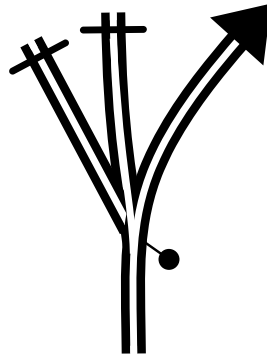

105,74

3,44

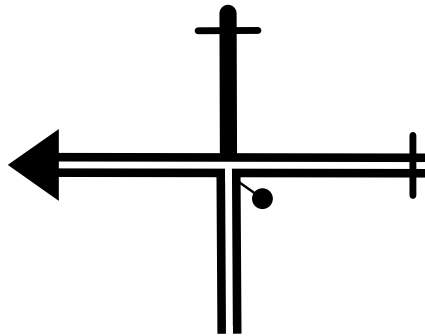

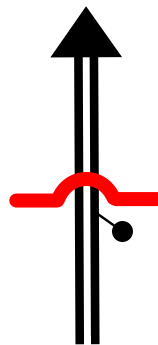

106,46

0,72

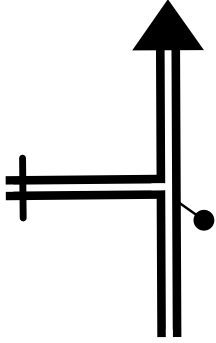
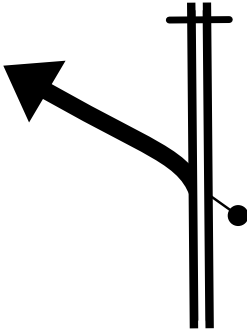
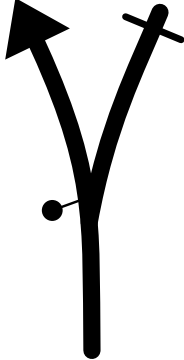

Next 0,79

11	RALLY JAMEEL 2024 / DAY 1 Tuesday HAIL SERVICE OUT - ROAD SECTION A / 109,06 km	Km : 1,81
<p data-bbox="60 210 459 353">107,25</p> <p data-bbox="73 412 264 517">0,79</p>		
<p data-bbox="60 602 459 745">109,00</p> <p data-bbox="73 804 264 909">1,75 ↓</p>		
<p data-bbox="60 994 459 1137">109,06</p> <p data-bbox="73 1196 264 1301">0,06</p>		<p data-bbox="1214 981 1501 1151">  TC 1 SS Hail-AI Ula </p> <p data-bbox="1177 1256 1554 1294"> <small>N27°31.855 E41°05.175</small> 0 </p>

Next

0,00
0,00

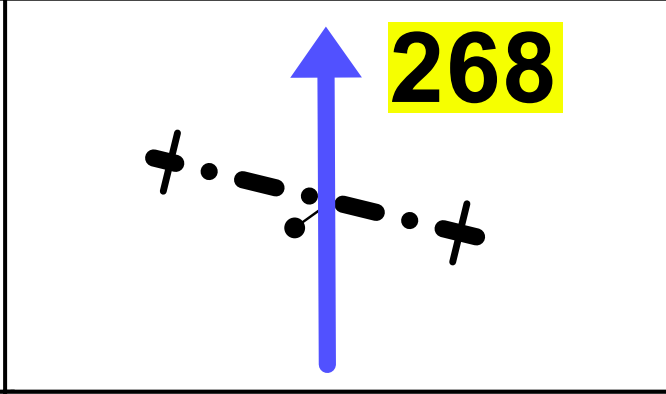

DSS1
Average Speed Challenge START
Average speed 36km/h !

N27°31.855 E41°05.060 1

0,58
0,58

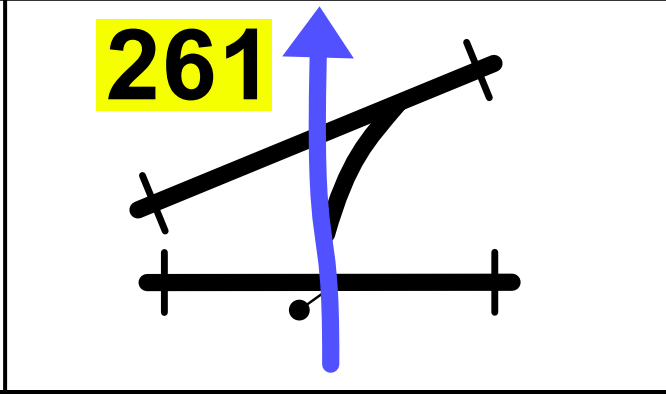

P//
NBX
CROSS ROAD!

1,60
1,02 M

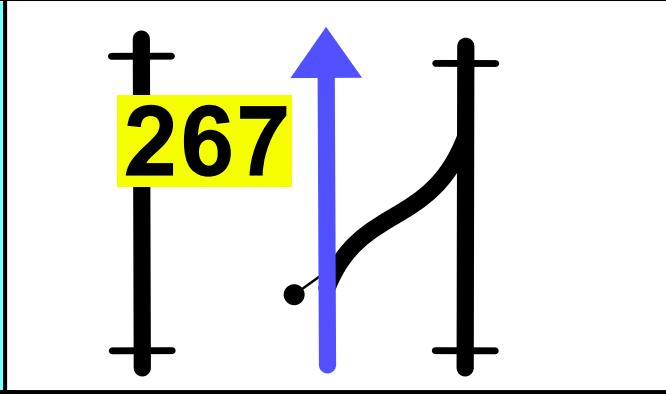

P//

1.1

2,15
0,55

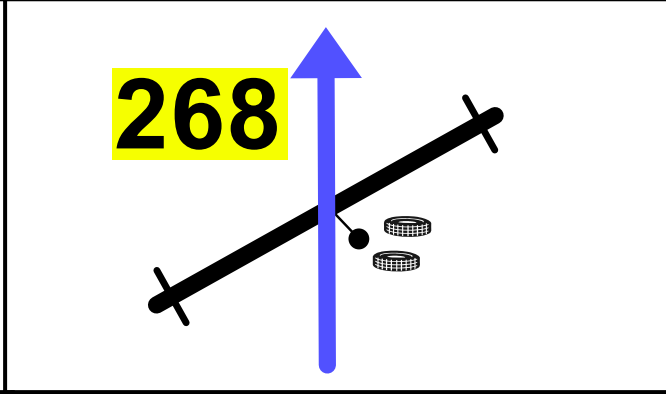

P//

<u>3,47</u>
1,32 M

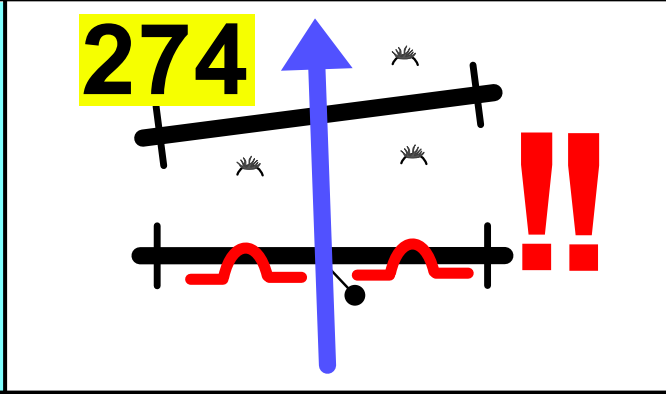

PP
NBX
CROSS ROAD!
Into Dunette

1.2

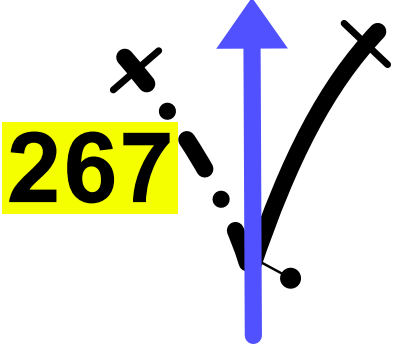
5,04	 <p style="font-size: 2em; font-weight: bold; background-color: yellow; display: inline-block; padding: 2px;">267</p>	NBX CROSS ROAD!
1,57		

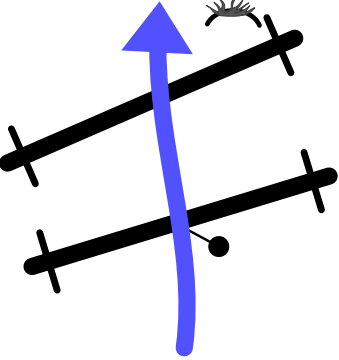
5,39		!
0,35 ↓		

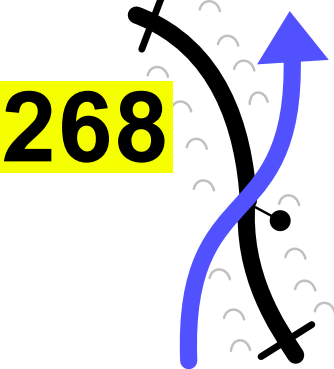
5,59	 <p style="font-size: 2em; font-weight: bold; background-color: yellow; display: inline-block; padding: 2px;">268</p>	2
0,20	M	

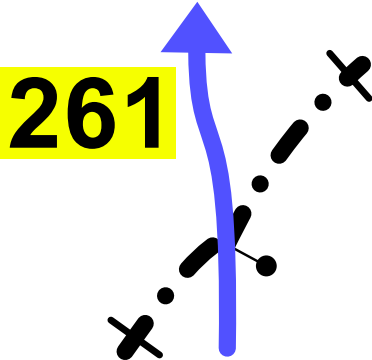
6,09	 <p style="font-size: 2em; font-weight: bold; background-color: yellow; display: inline-block; padding: 2px;">261</p>	
0,50		

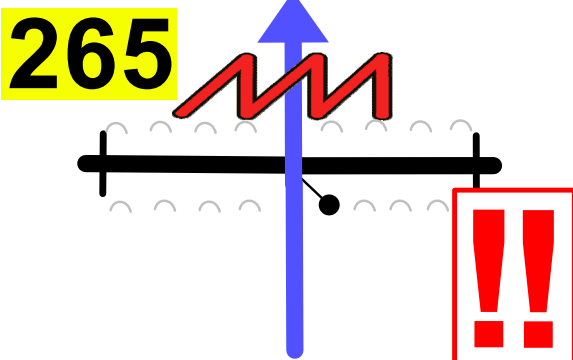
6,53	 <p style="font-size: 2em; font-weight: bold; background-color: yellow; display: inline-block; padding: 2px;">265</p>	ET 300m 252 PP NBX CROSS ROAD!
0,44		

Next 3,00

9,53	251	NBX CROSS ROAD!
3,00		

12,97	247 C	
3,44		

14,28	251	NBX CROSS ROAD!
1,31		

15,27	269 C	PP
0,99 (M)		(3)

16,28	250	
1,01		

Next 1,06

17,34

1,06 ↓ (M)

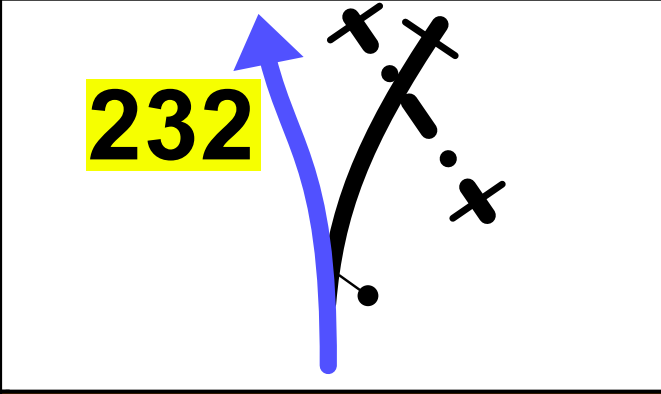

Average Speed
Challenge
FINISH

4

17,60

0,26 ↓ (DZ)

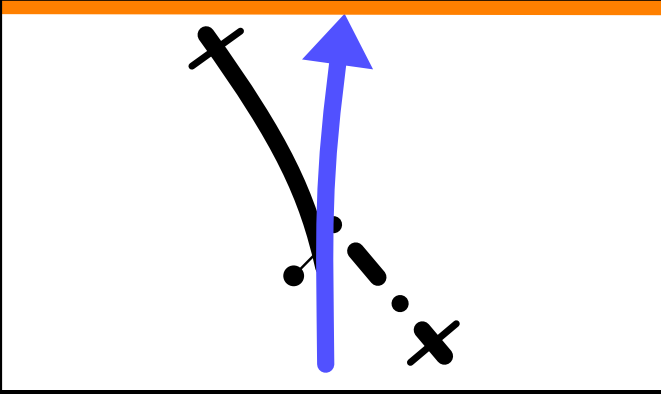

30

5

17,77

0,17 ↓

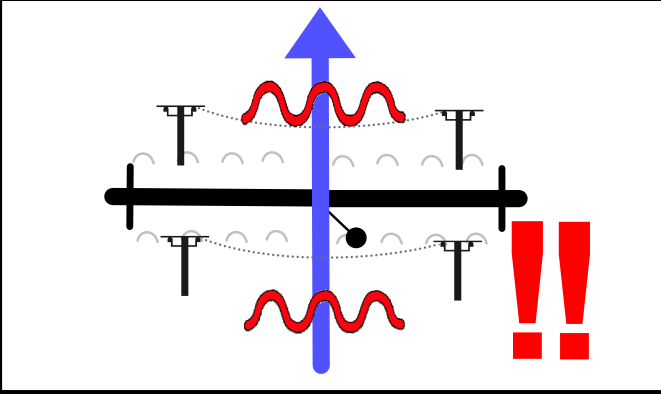

30

17,85

0,08 ↓

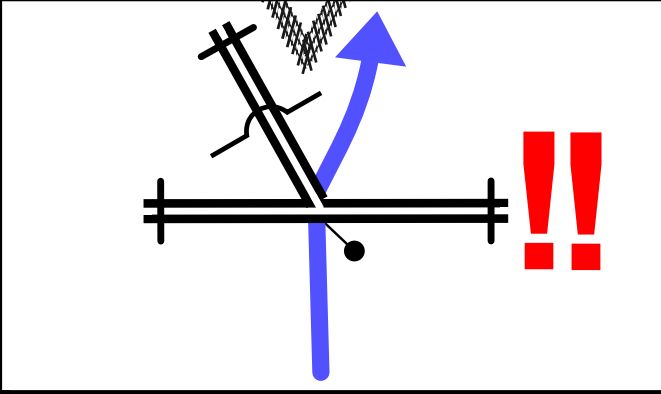

30

18,03

0,18

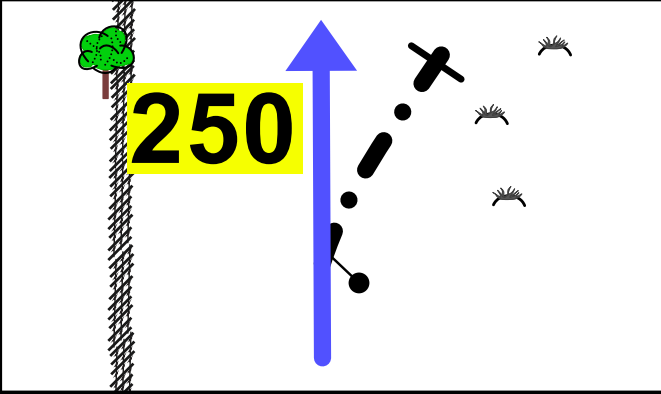

30

<p style="font-size: 2em; font-weight: bold;">18,60</p> <p style="font-size: 1.5em; font-weight: bold;">0,57 ↓</p> <p style="font-size: 1.5em; font-weight: bold;">(FZ)</p>	<p style="font-size: 1.5em; font-weight: bold; background-color: yellow;">245</p>	<p style="font-size: 2em; font-weight: bold;">30</p> <p style="text-align: right; font-size: 1.5em; font-weight: bold;">(6)</p>
---	---	---

<p style="font-size: 2em; font-weight: bold;">18,83</p> <p style="font-size: 1.5em; font-weight: bold;">0,23</p>	<p style="font-size: 1.5em; font-weight: bold; background-color: yellow;">229 C</p>	
--	---	--

<p style="font-size: 2em; font-weight: bold;">19,49</p> <p style="font-size: 1.5em; font-weight: bold;">0,66</p> <p style="font-size: 1.5em; font-weight: bold;">(M)</p>	<p style="font-size: 1.5em; font-weight: bold; background-color: yellow;">186</p>	<p style="text-align: right; font-size: 1.5em; font-weight: bold;">(7)</p>
--	---	--

<p style="font-size: 2em; font-weight: bold;">19,87</p> <p style="font-size: 1.5em; font-weight: bold;">0,38</p>	<p style="font-size: 1.5em; font-weight: bold; background-color: yellow;">230</p>	<p style="font-size: 1.5em; font-weight: bold;">NBX CROSS ROAD!</p>
--	---	---

<p style="font-size: 2em; font-weight: bold;">20,84</p> <p style="font-size: 1.5em; font-weight: bold;">0,97</p> <p style="font-size: 1.5em; font-weight: bold;">(M)</p>	<p style="font-size: 1.5em; font-weight: bold; background-color: yellow;">252 A</p>	<p style="font-size: 1.5em; font-weight: bold;">P// PP NBX CROSS ROAD!</p> <p style="text-align: right; font-size: 1.5em; font-weight: bold;">(8)</p>
--	---	---

Next 3,01

23,85

3,01

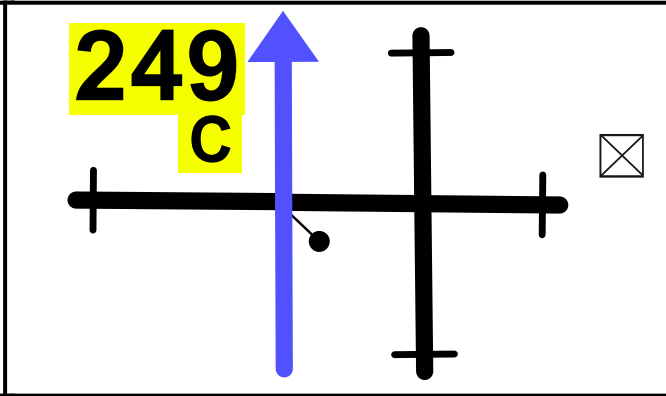

P//

24,46

0,61

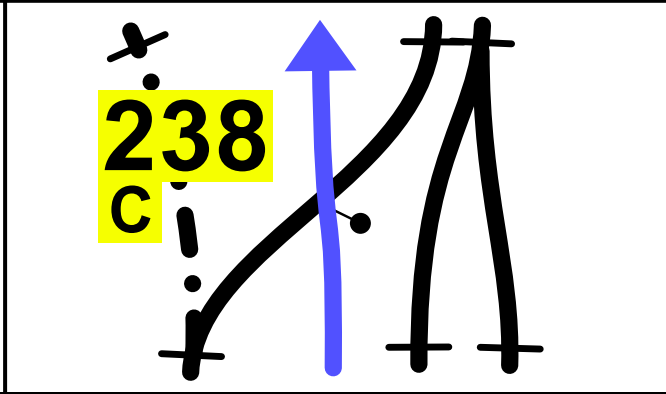

P//

25,29

0,83

M

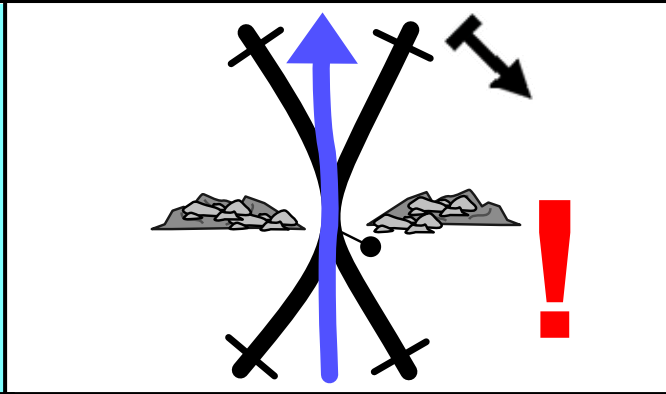

PP P//

9

26,72

1,43

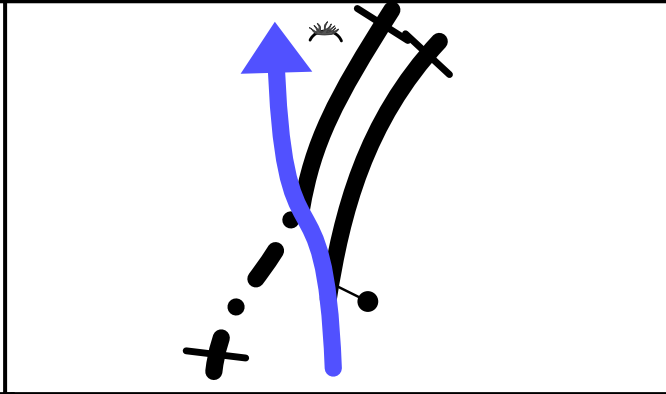

P//

27,92

1,20

M

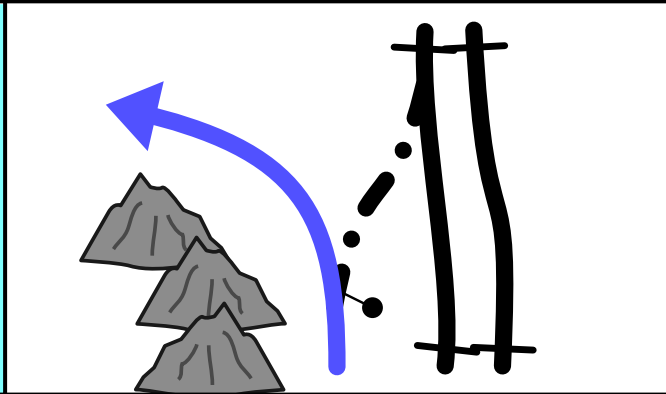

P//

ET

113

10

29,56

1,64

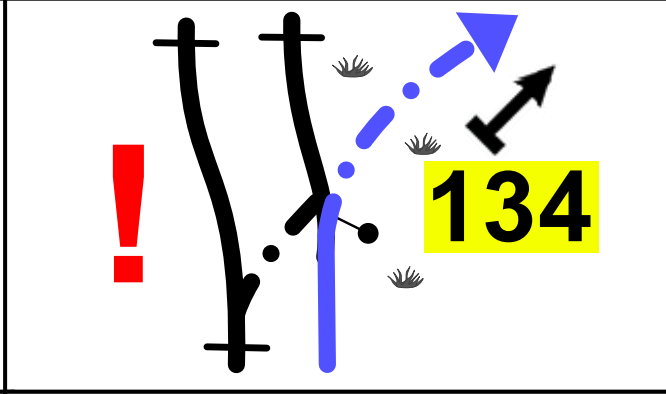

30,29

0,73

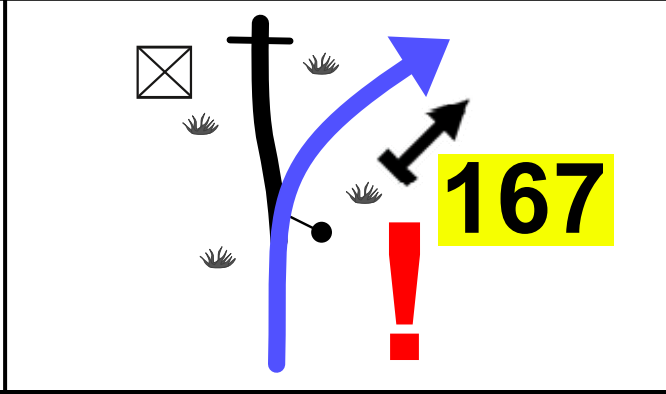

30,61

0,32

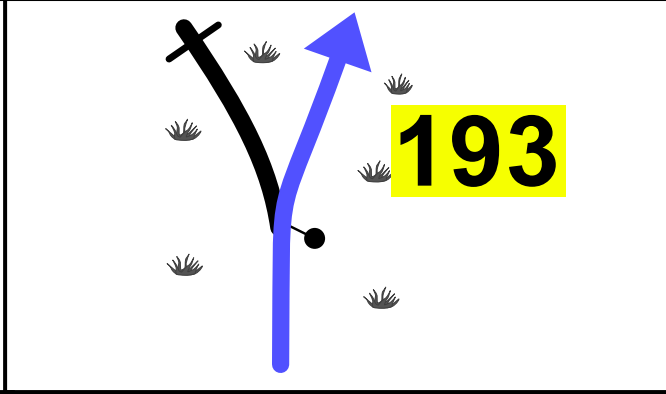

31,56

0,95

M

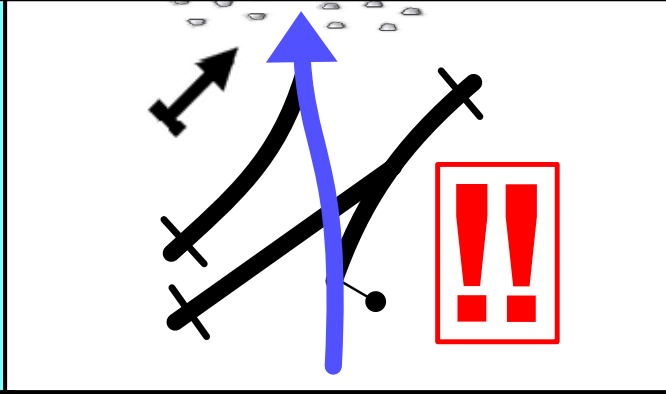

ET

200m

Rock!

S

10.1

32,15

0,59

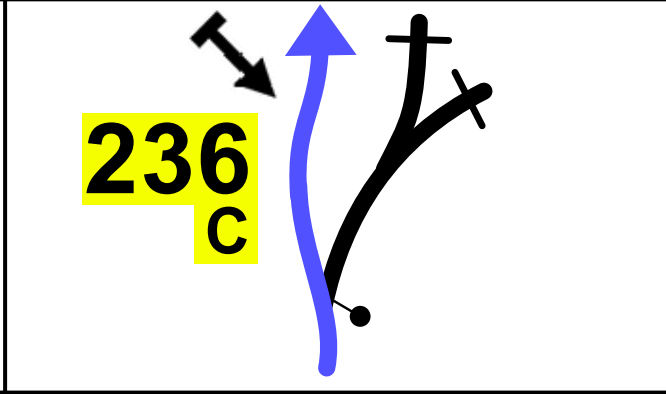

P//

32,47

0,32 ↓

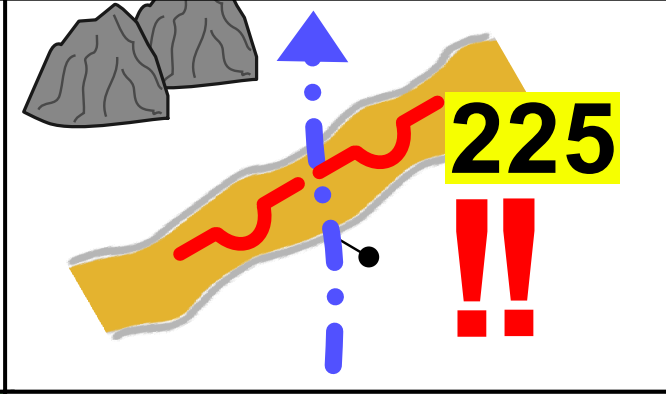

P//

32,68

0,21

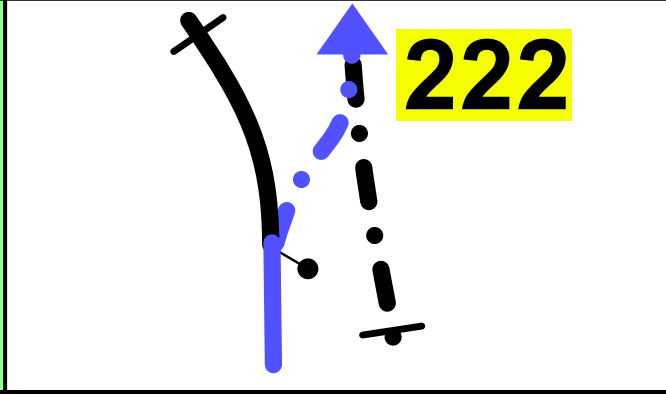

P//

33,05

0,37

M

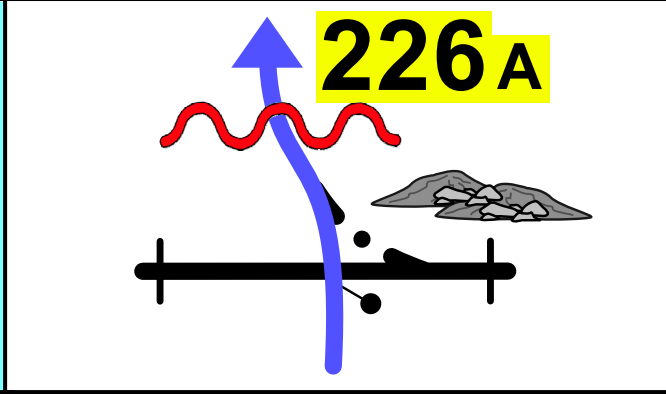

11

33,44

0,39

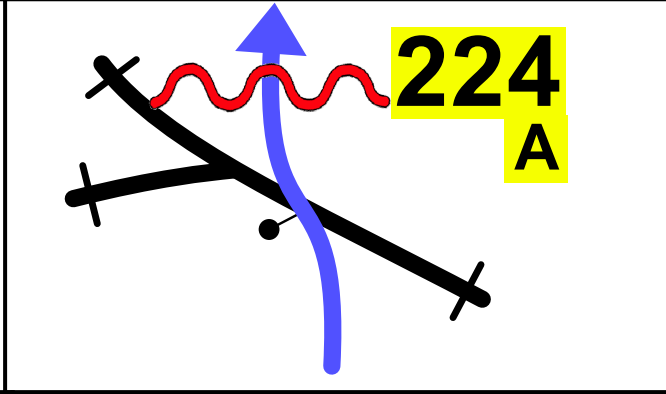

STONES!

NBX
CROSS ROAD!

34,73

1,29

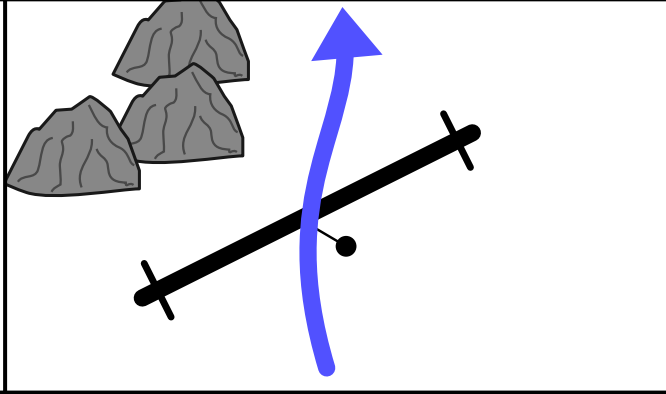

STONES!

20

RALLY JAMEEL 2024 / DAY 1 Tuesday
SS1 HAIL - AL ULA / 141,56 km

Km : 106,53

35,03

200
C

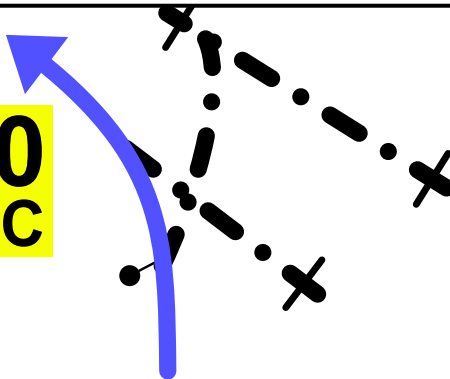

PP

0,30



12

35,63

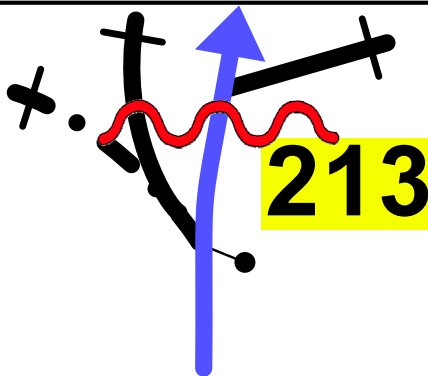

P//
NBX
CROSS ROAD!

0,60

36,26

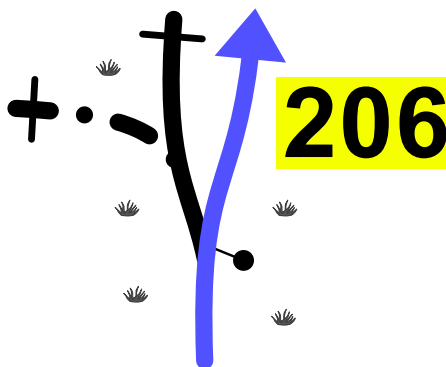

0,63

37,40

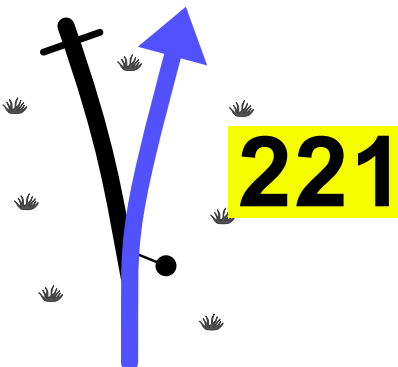

1,14 ↓

37,54

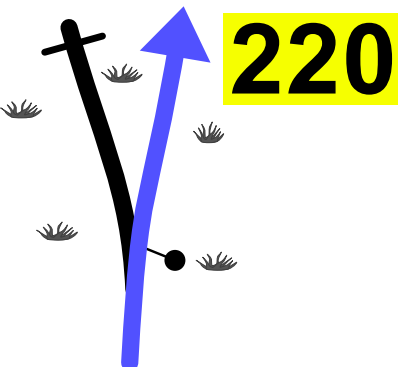

0,14 ↓

Next 0,20

21

RALLY JAMEEL 2024 / DAY 1 Tuesday
SS1 HAIL - AL ULA / 141,56 km

Km : 103,82

37,74

0,20

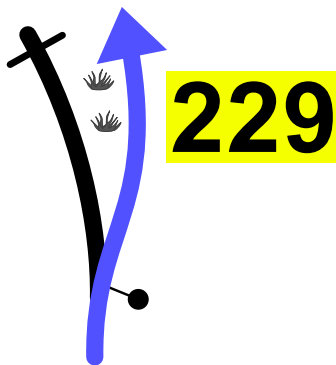

OBLIC 195

38,16

0,42

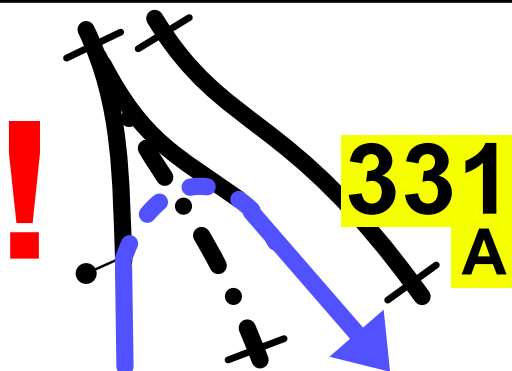

13

38,76

0,60 ↓

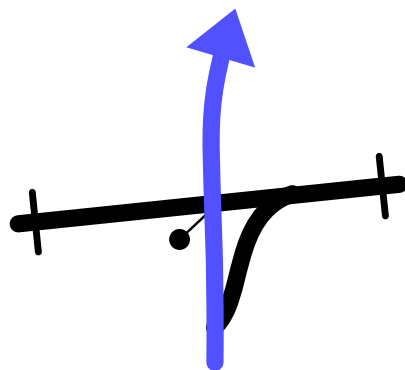

38,93

0,17

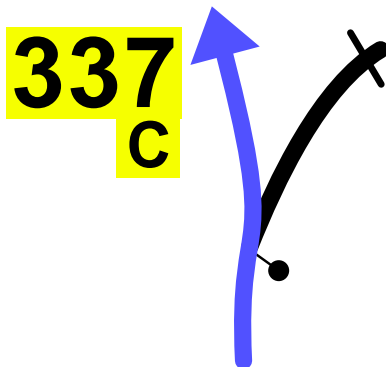

P//
NBX
CROSS ROAD!

40,06

1,13

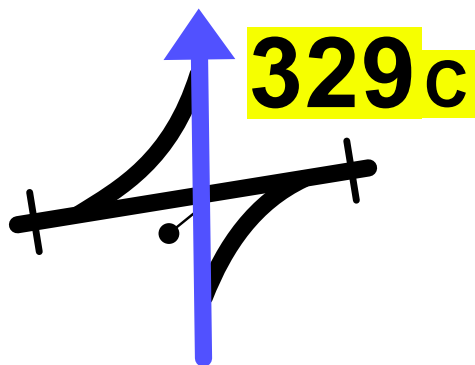

Next 0,39

Danger 2

40,45

0,39

M

244
C

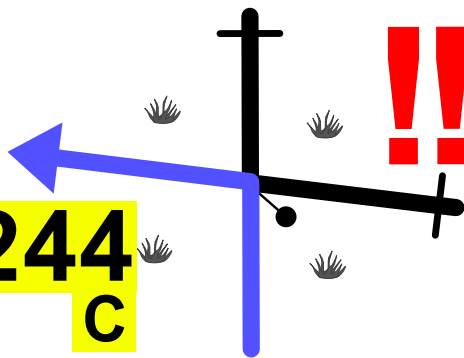

14

41,15

0,70

226

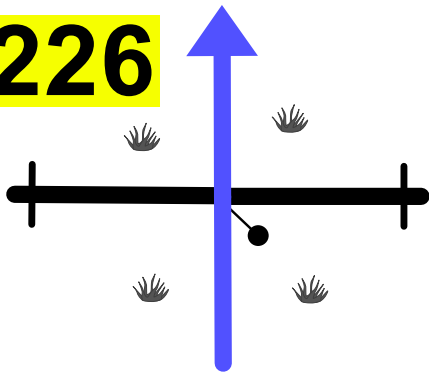

S

41,83

0,68

222

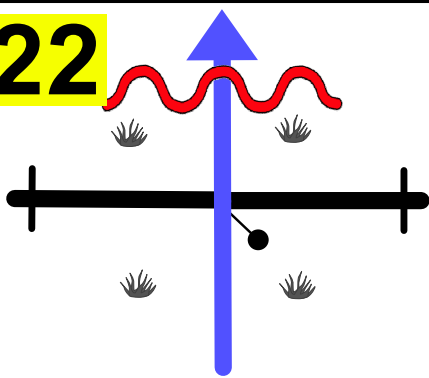

S PP

43,14

1,31

216

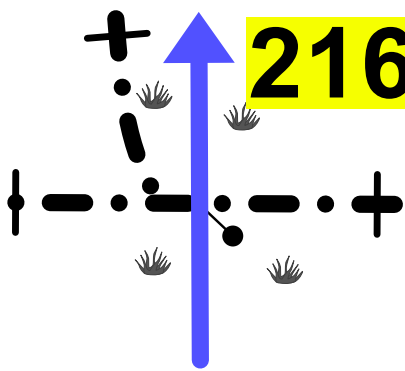

44,29

1,15

233

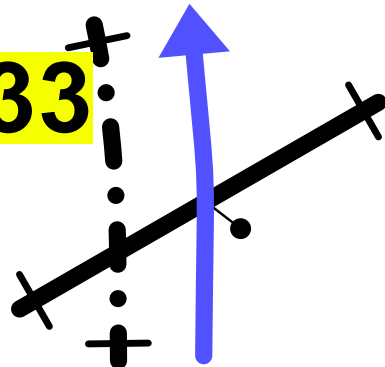

Next 0,57

23

RALLY JAMEEL 2024 / DAY 1 Tuesday
SS1 HAIL - AL ULA / 141,56 km

Km : 96,70

44,86

0,57

(M)

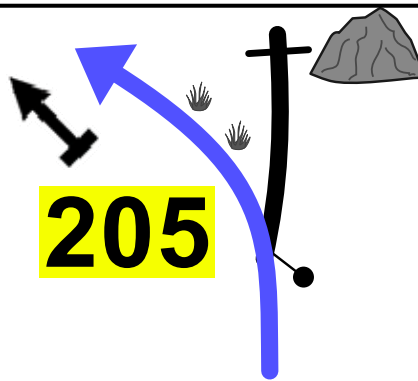

OBLIC 169

(15)

45,46

0,60 ↓

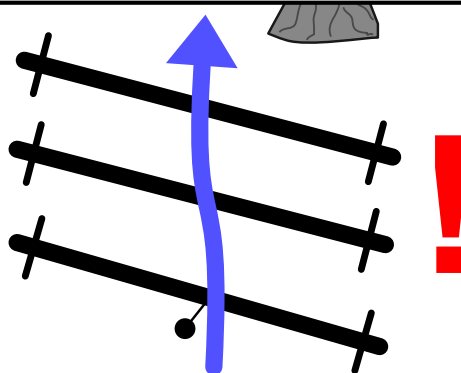

45,71

0,25

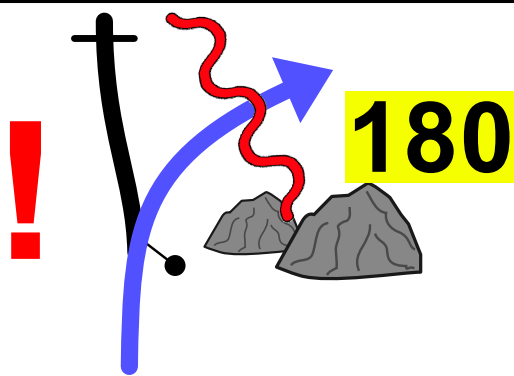

P//

OBLIC 226

46,42

0,71 ↓

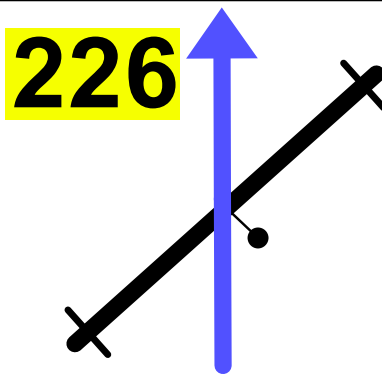

46,63

0,21

(M)

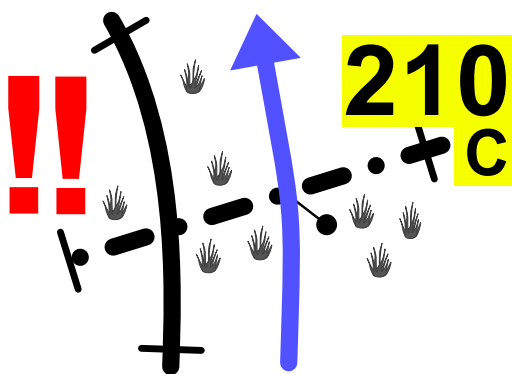

P//

(16)

Next 0,31

24

RALLY JAMEEL 2024 / DAY 1 Tuesday
SS1 HAIL - AL ULA / 141,56 km

Km : 94,62

46,94

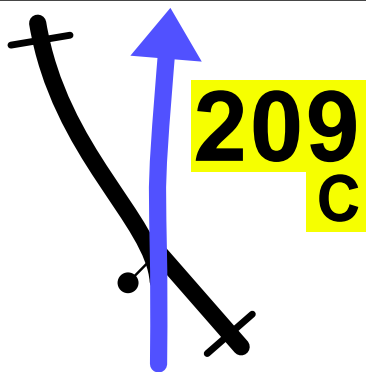

P// PP

0,31

47,62

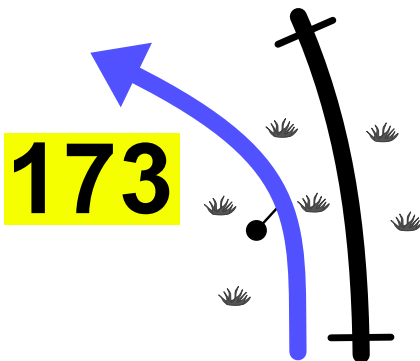

0,68

47,92

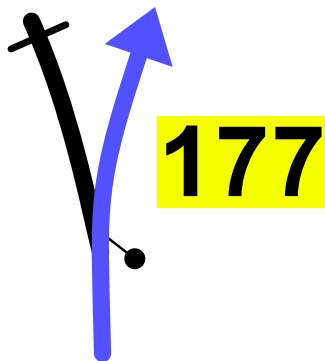

NBX
CROSS ROAD!

0,30



48,24

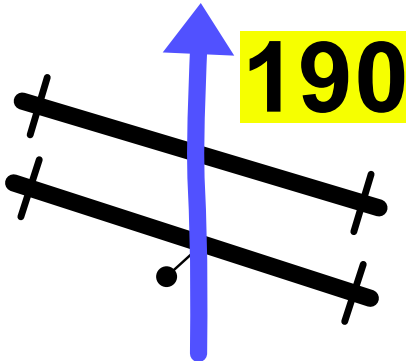

0,32 ↓

48,48

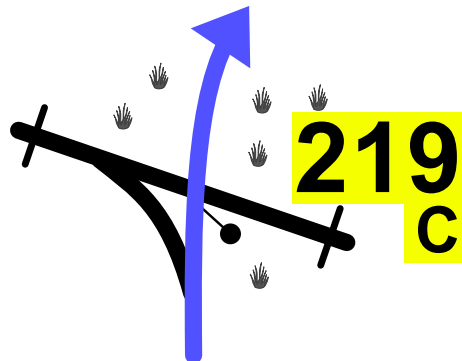

PP

0,24

Next 1,82

25

RALLY JAMEEL 2024 / DAY 1 Tuesday
SS1 HAIL - AL ULA / 141,56 km

Km : 91,26

50,30

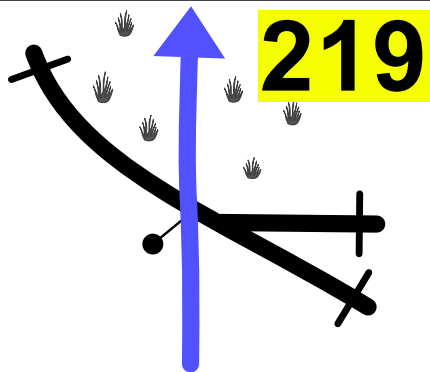

1,82

M

18

51,05

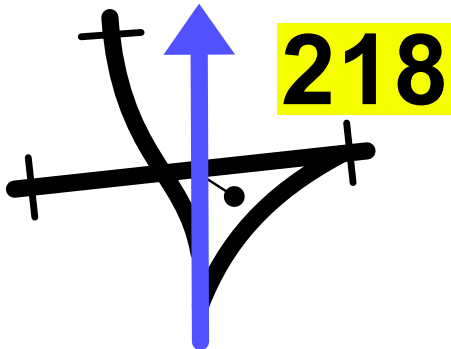

P// PP

0,75 ↓

51,33

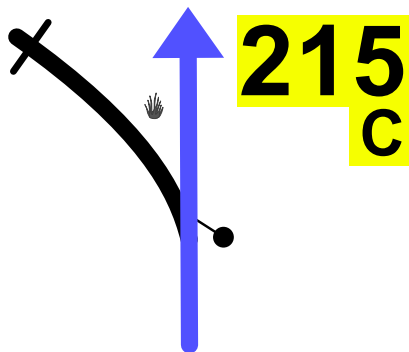

P// PP

0,28

51,84

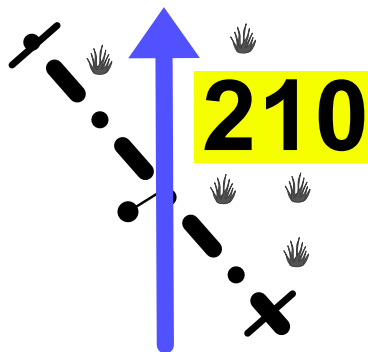

0,51

52,31

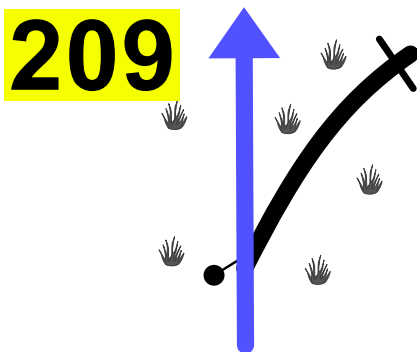

P//

0,47

Next 1,06

26

RALLY JAMEEL 2024 / DAY 1 Tuesday
SS1 HAIL - AL ULA / 141,56 km

Km : 88,19

53,37

1,06

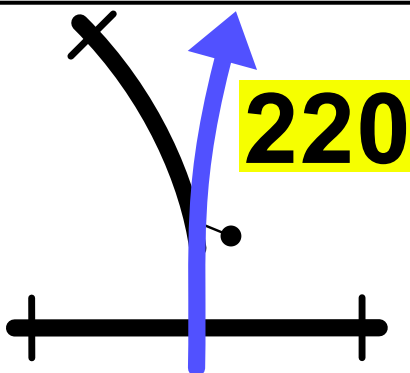

P//
NBX
CROSS ROAD!



54,41

1,04

214

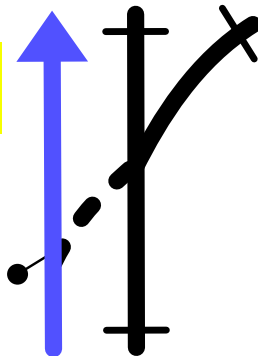

P//

54,81

0,40 ↓

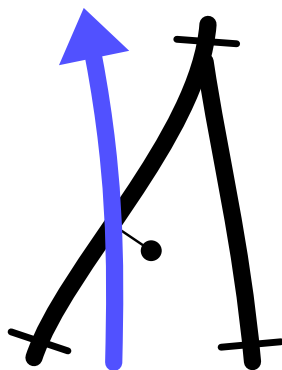

P//

55,01

0,20



211
C

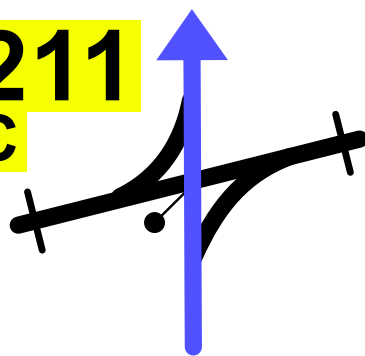

NBX
CROSS ROAD!



56,88

1,87

212

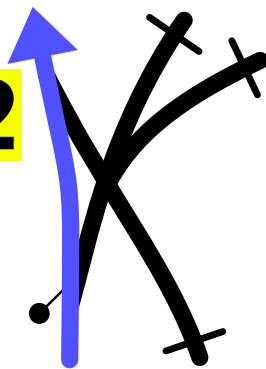

P// PP
NBX
CROSS ROAD!

Next 1,70

27

RALLY JAMEEL 2024 / DAY 1 Tuesday
SS1 HAIL - AL ULA / 141,56 km

Km : 82,98

58,58

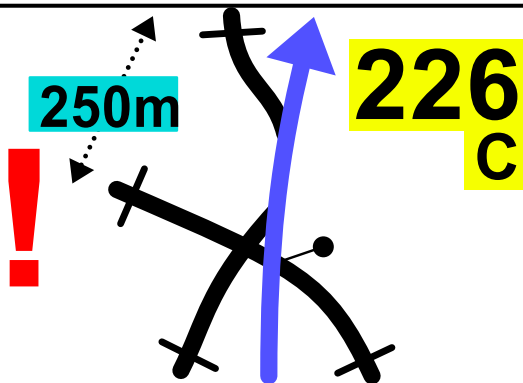

PP

1,70

60,23

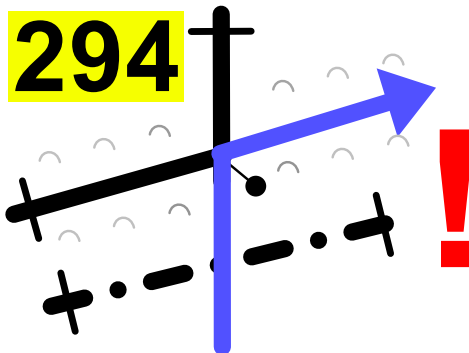

P//

1,65

(M)

PP

(20)

61,46

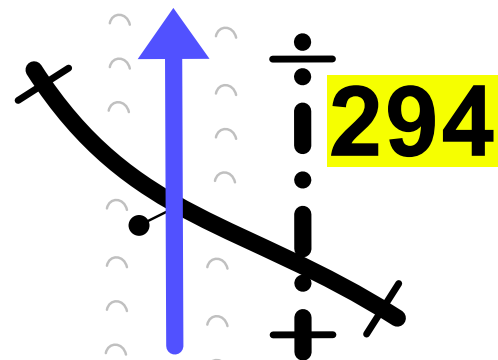

P//

1,23

62,65

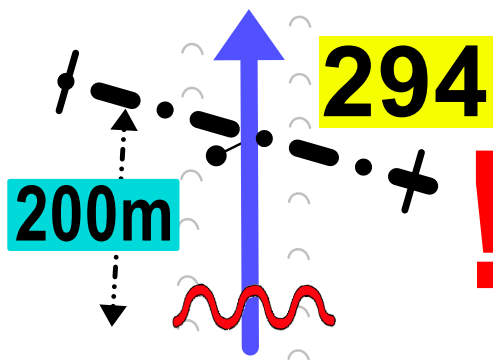

1,19

63,51

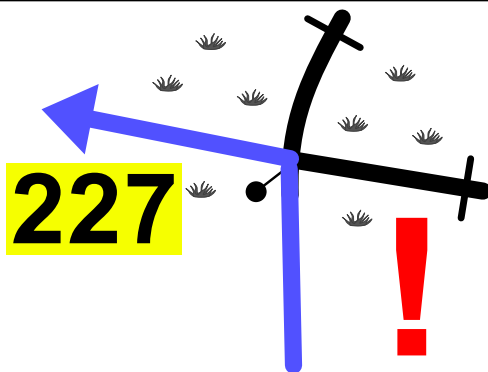

0,86

(M)

(21)

Next 0,54

64,05

247

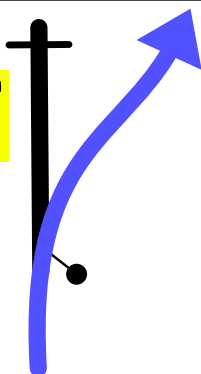

S PP

0,54

64,42

262

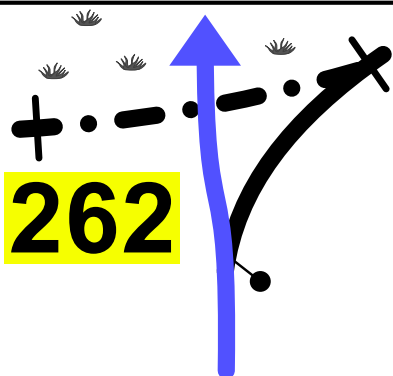

→ 281

0,37

65,05

223

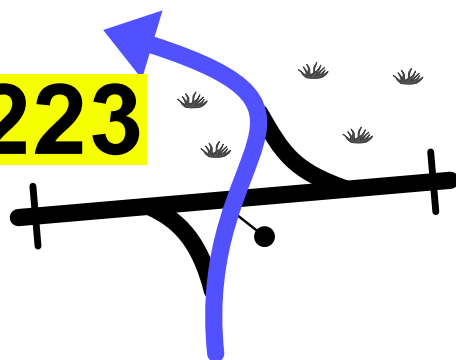

S

0,63 ↓ (M)

(22)

65,26

195

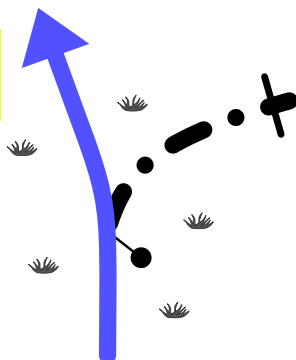

0,21

65,59

!!

226

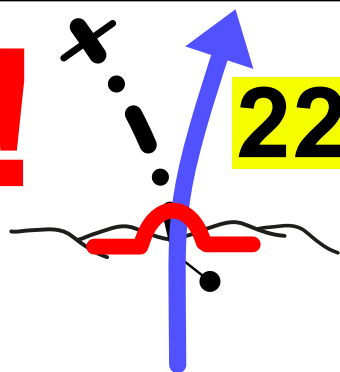

Stones!

0,33

Next 0,46

29

RALLY JAMEEL 2024 / DAY 1 Tuesday
SS1 HAIL - AL ULA / 141,56 km

Km : 75,51

66,05

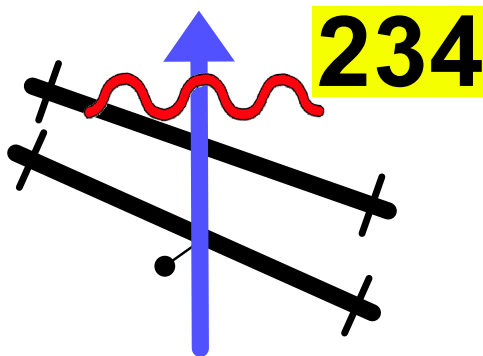

NBX
CROSS ROAD!

0,46

67,01

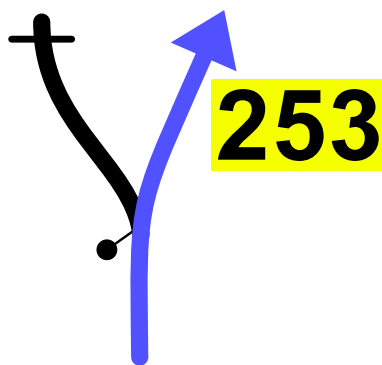

0,96

67,50

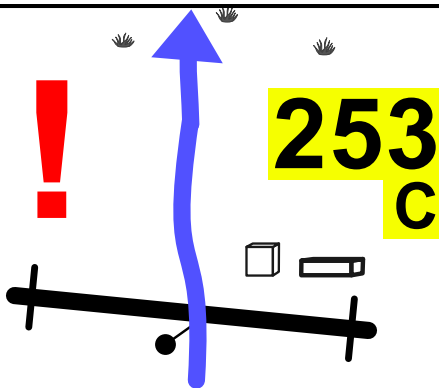

0,49 ↓

67,67

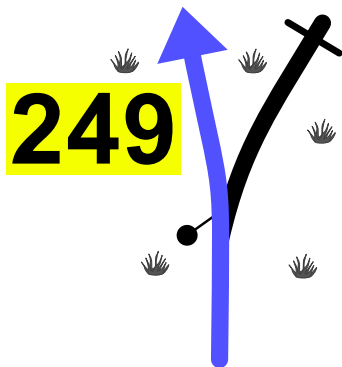

PP

0,17

NBX
CROSS ROAD!

68,21

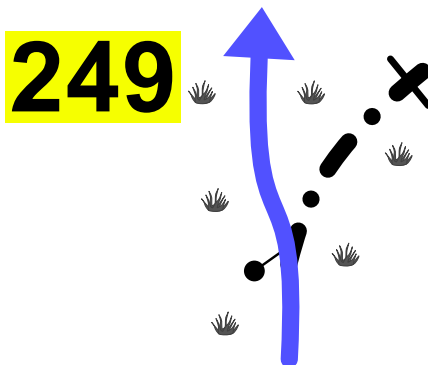

→ 216

0,54 ↓

NBX
CROSS ROAD!

Next 0,28

68,49

0,28 ↓ (M)

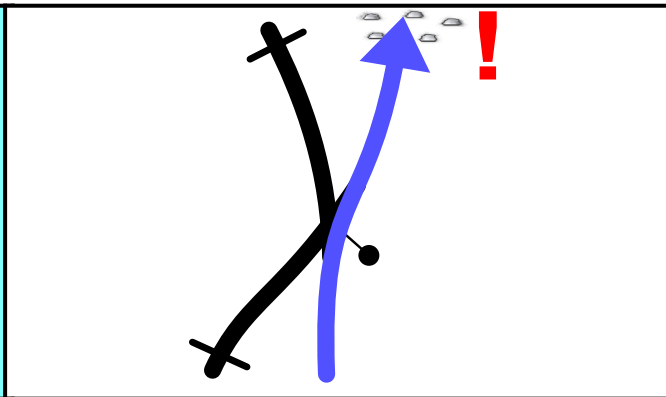

Stones!

23

68,69

0,20

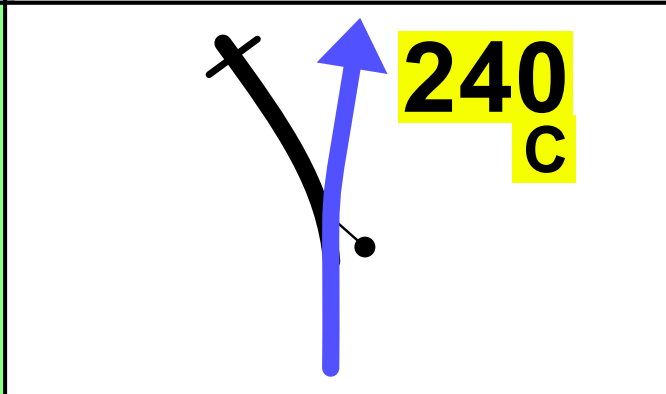

S PP

P//

69,08

0,39

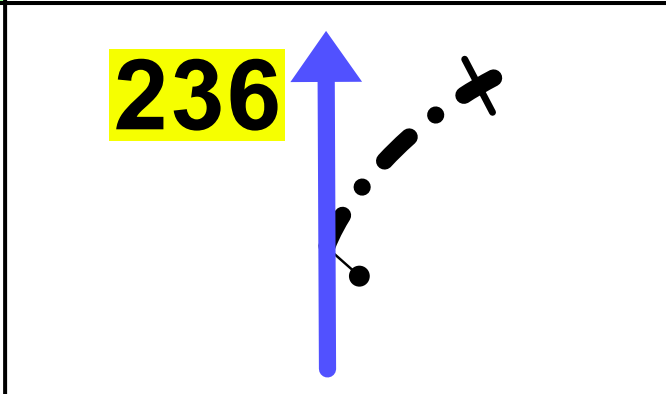

PP

69,67

0,59

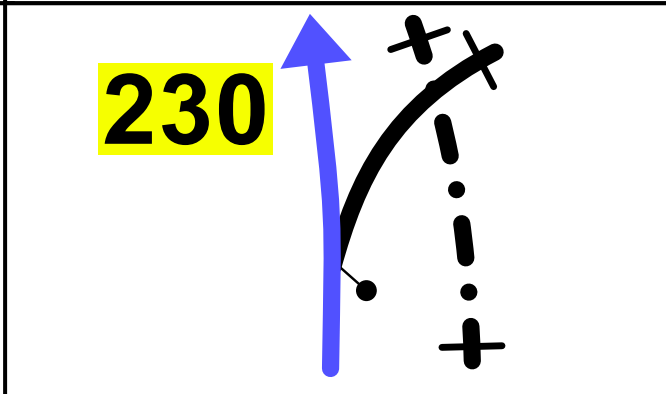

P//



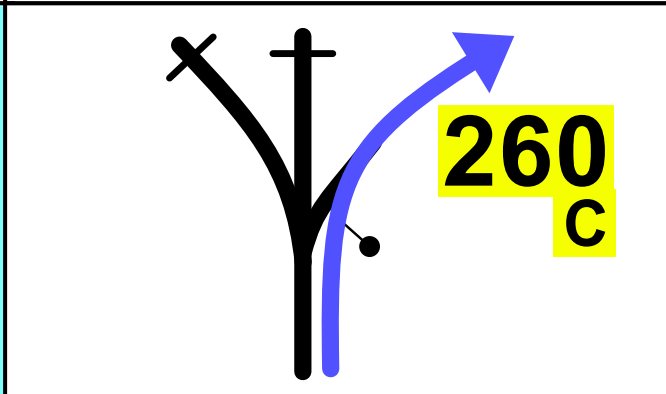

70,14

0,47 (M)

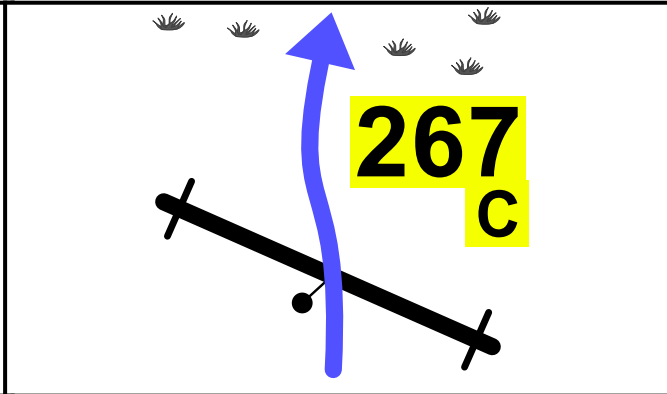

P//
NBX
CROSS ROAD!

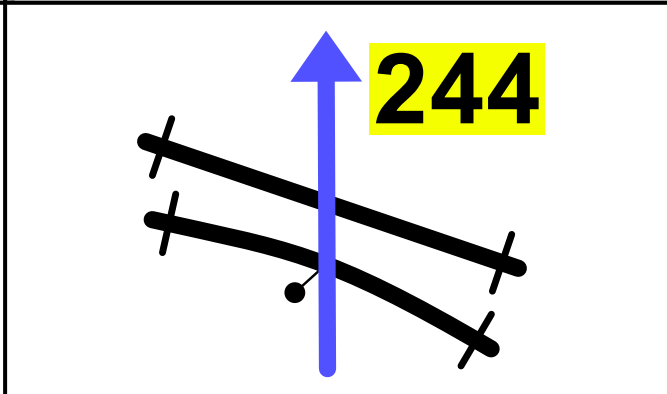
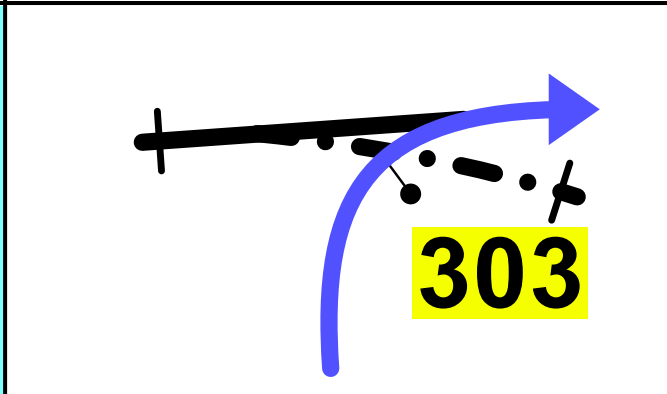
24

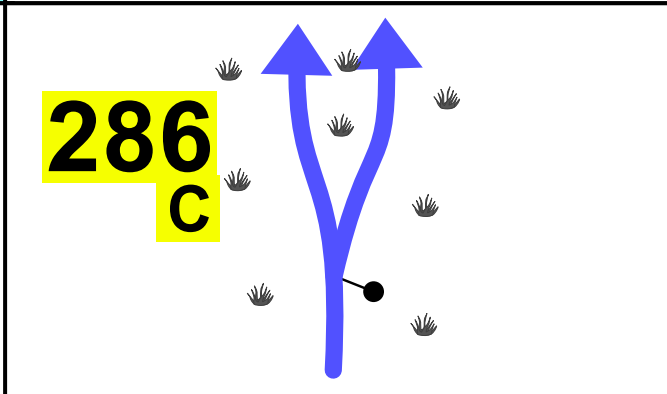
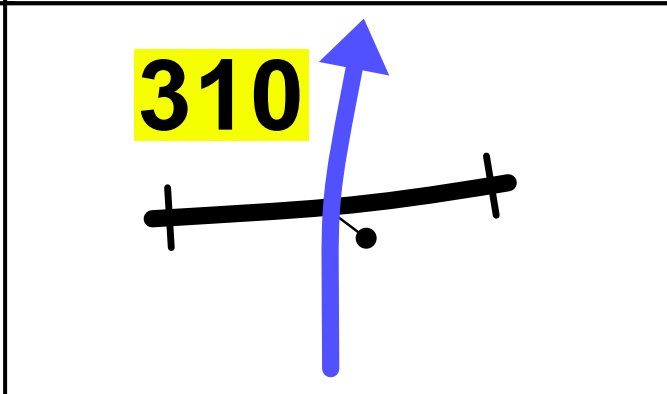
31	RALLY JAMEEL 2024 / DAY 1 Tuesday SS1 HAIL - AL ULA / 141,56 km	Km : 70,86
<p>70,70</p>		<p>Average Speed Challenge START </p> <p><i>Average speed 39km/h !</i></p>
<p>0,56</p>		
<p>71,58</p>		<p></p> <p>P// PP 25</p>
<p>71,98</p> <p>0,40 M</p>		<p>P//</p>
<p>72,99</p> <p>1,01</p>		<p>P//</p>
<p>74,50</p> <p>1,51 ↓</p>		

Next 0,16

74,66

0,16

300

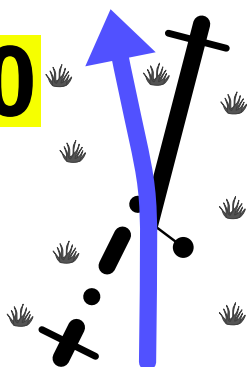

PP P//

75,73

1,07

(M)

299

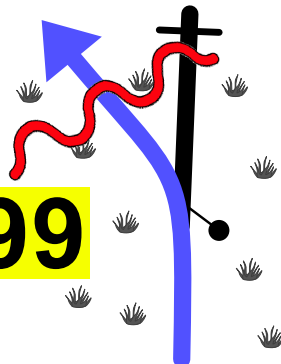

(26)

77,36

1,63

232
C

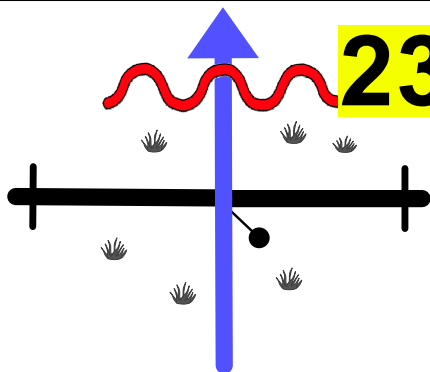

PP
S

78,03

0,67

(M)

294

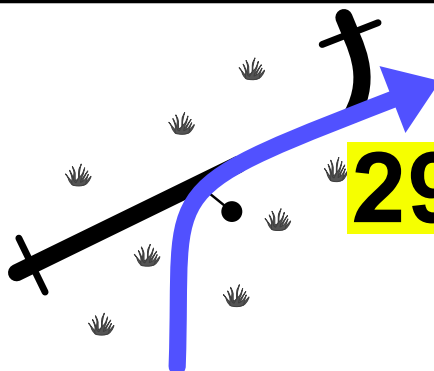

(27)

78,85

0,82

301
C

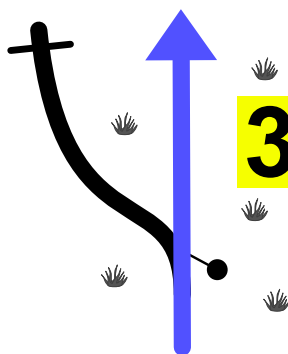

PP
NBX
CROSS ROAD!

33

RALLY JAMEEL 2024 / DAY 1 Tuesday
SS1 HAIL - AL ULA / 141,56 km

Km : 61,08

80,48

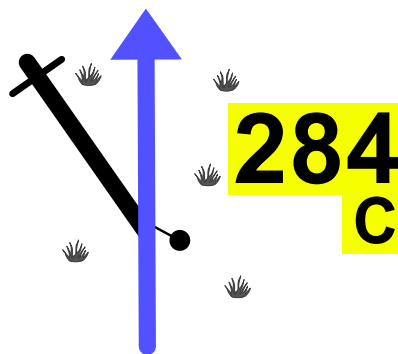

PP

1,63

81,32

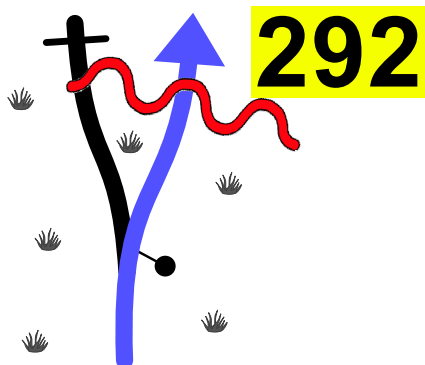

S P//

0,84

81,92

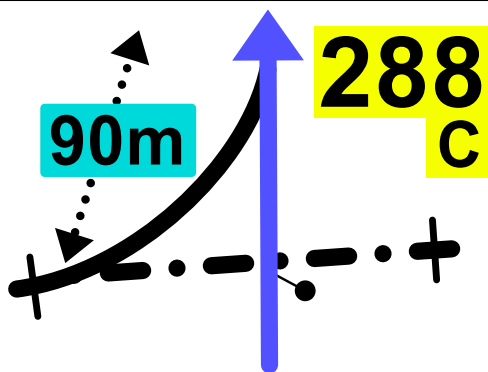

P//

0,60

82,58

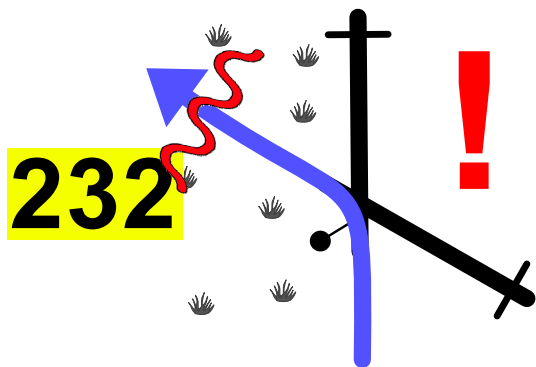

PP

0,66

(M)

(28)

84,74

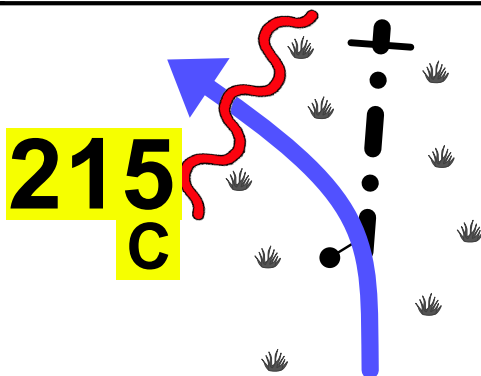

S

2,16

Next 0,70

34

RALLY JAMEEL 2024 / DAY 1 Tuesday
SS1 HAIL - AL ULA / 141,56 km

Km : 56,12

85,44

0,70

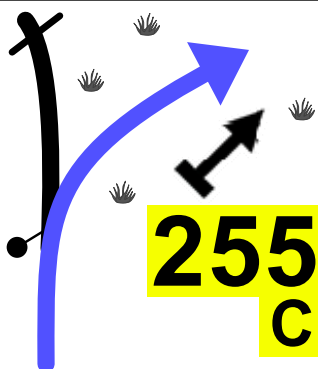

 PP

85,99

0,55

M

222

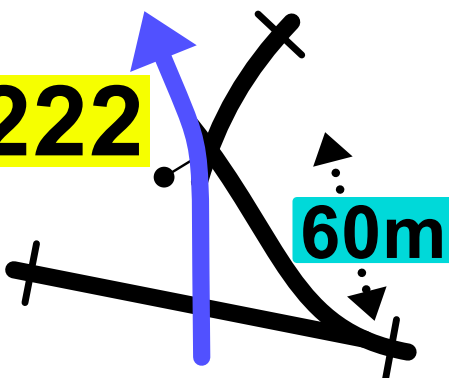

NBX
CROSS ROAD!

29

86,93

0,94 ↓

200

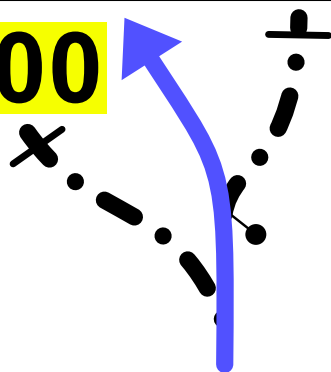



87,19

0,26

199

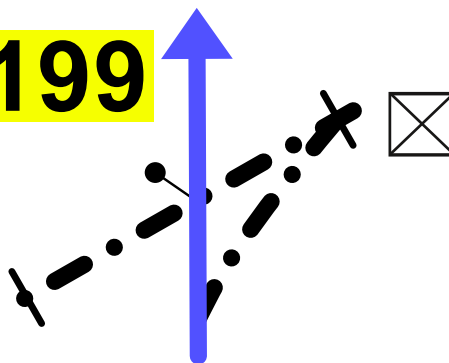

NBX
CROSS ROAD!

87,52

0,33

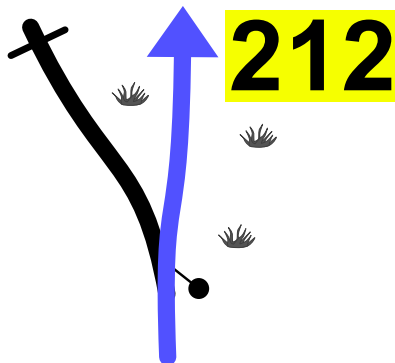

Next 0,36

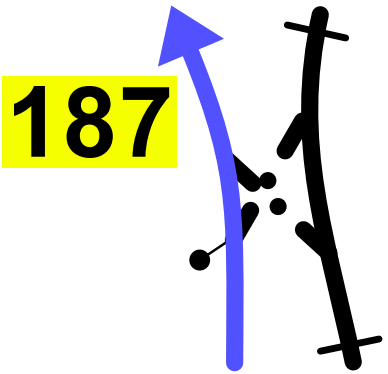
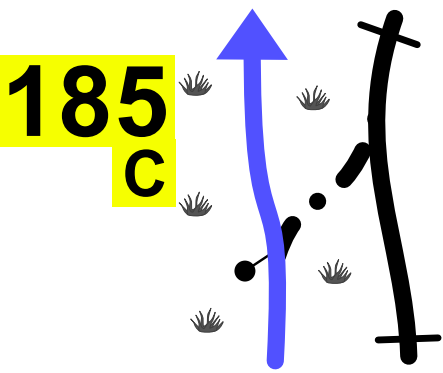
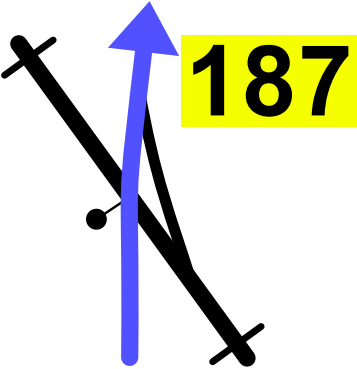
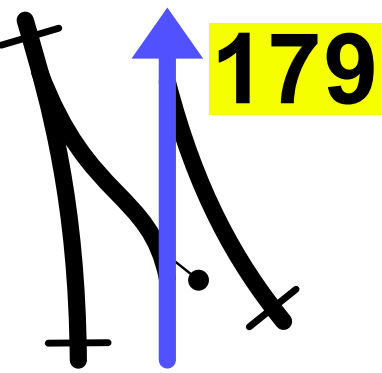
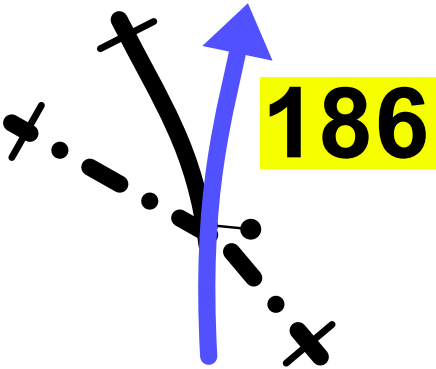
35	RALLY JAMEEL 2024 / DAY 1 Tuesday SS1 HAIL - AL ULA / 141,56 km	Km : 53,68
<p>87,88</p> <p>0,36</p>		<p>P//</p>
<p>88,47</p> <p>0,59 (M)</p>		<p>P//</p> <p>(30)</p>
<p>89,83</p> <p>1,36</p>		<p>PP P//</p>
<p>91,15</p> <p>1,32</p>		
<p>91,70</p> <p>0,55</p>		<p>OBLIC 167</p> <p>P//</p>

Next 3,02

36

RALLY JAMEEL 2024 / DAY 1 Tuesday
SS1 HAIL - AL ULA / 141,56 km

Km : 46,84

94,72

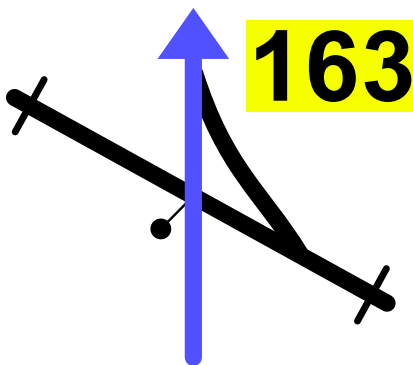

Average Speed
Challenge
FINISH 

P//

31

3,02



95,04

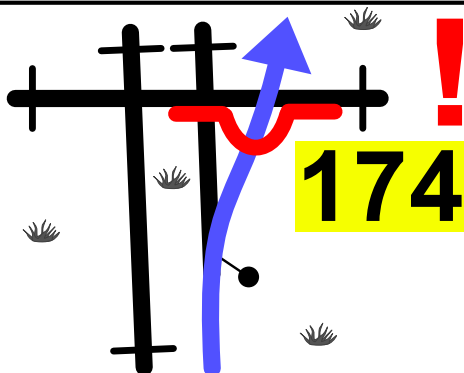

NBX
CROSS ROAD!

OBLIC 205

0,32

96,23

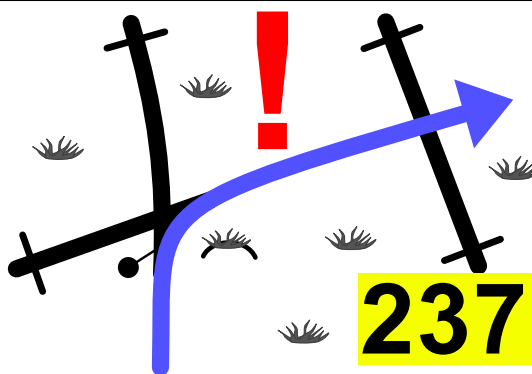

1,19

96,56

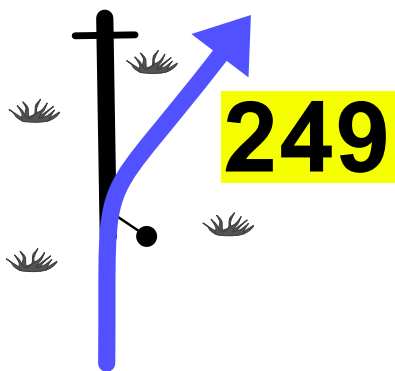

0,33

97,25

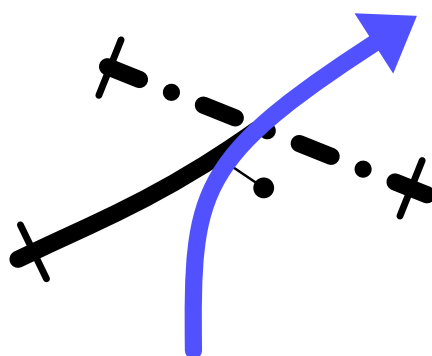

PP

0,69



32

Next 0,67

37

RALLY JAMEEL 2024 / DAY 1 Tuesday
SS1 HAIL - AL ULA / 141,56 km

Km : 43,64

97,92

0,67 ↓

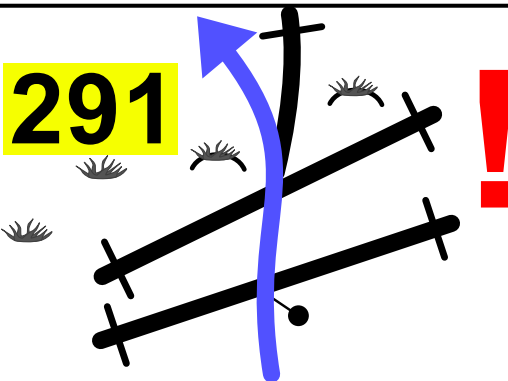

98,12

0,20

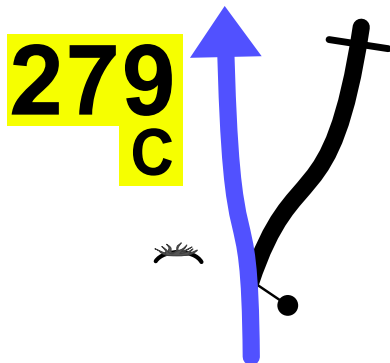

S PP

98,60

0,48

(M)

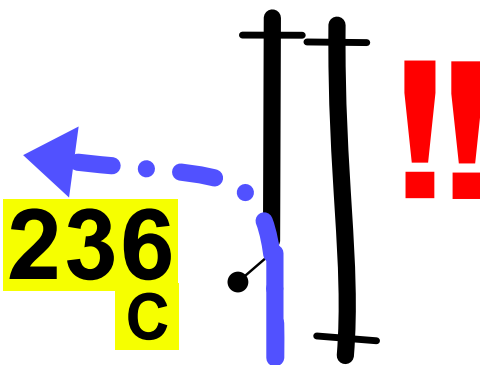

S

(33)

98,98

0,38

(M)

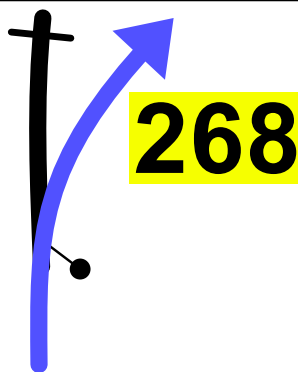

S

(34)

99,43



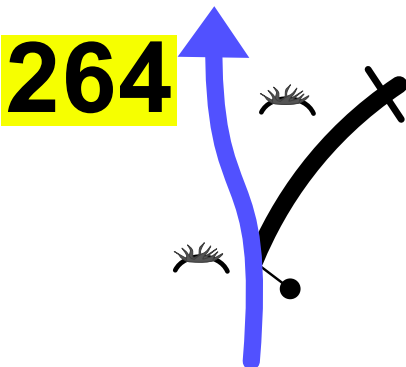



0,45

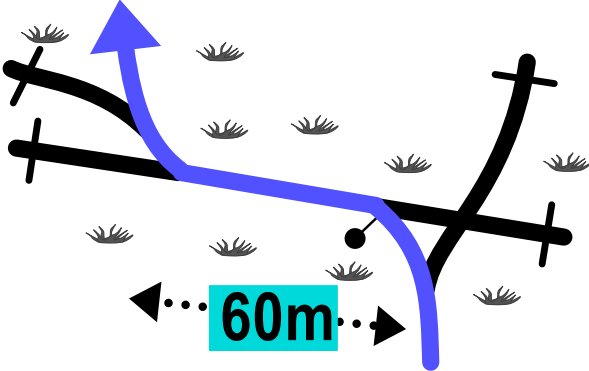

S PP

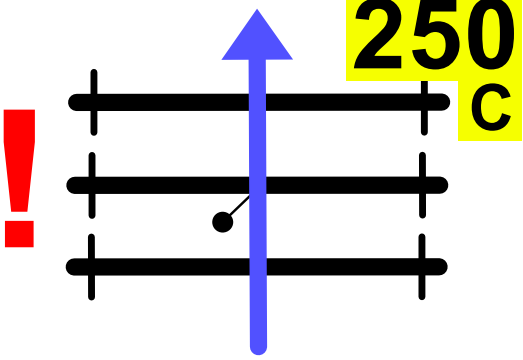
OBLIC 235

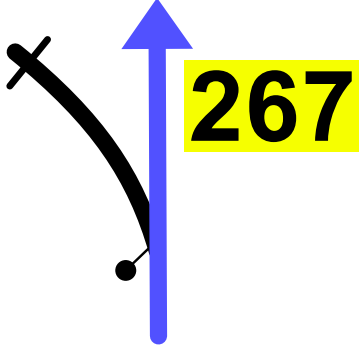
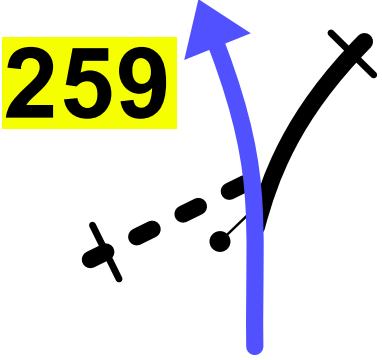
Next 0,74

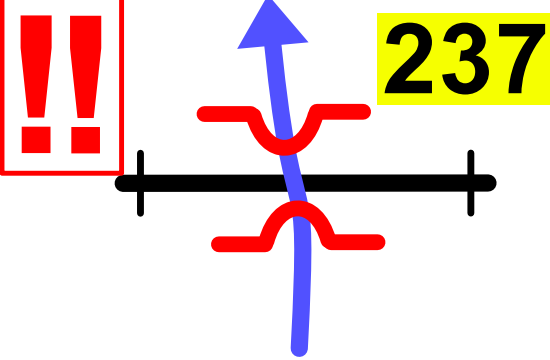
38	RALLY JAMEEL 2024 / DAY 1 Tuesday SS1 HAIL - AL ULA / 141,56 km	Km : 41,39
100,17		
0,74↓		NBX CROSS ROAD!  35
100,36		Stones!
0,19	M	
100,77		GV 
0,41↓		GV
100,95		
0,18↓		
<u>101,07</u>		
0,12↓		

Next 0,16

39

RALLY JAMEEL 2024 / DAY 1 Tuesday
SS1 HAIL - AL ULA / 141,56 km

Km : 40,33

101,23

0,16

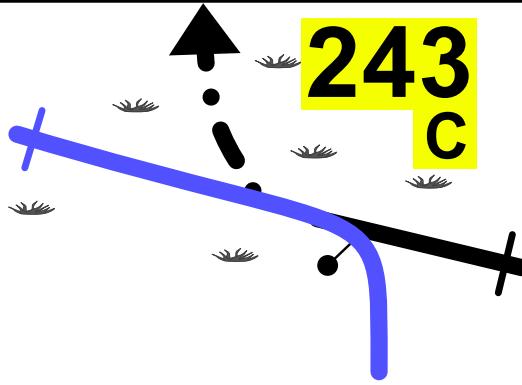

NBX
CROSS ROAD!

101,82

0,59

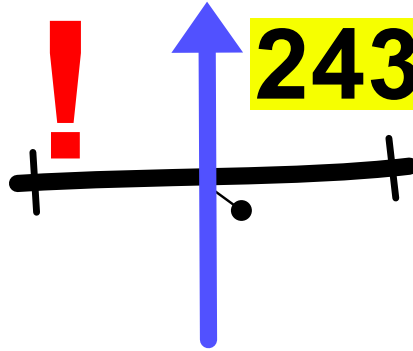

102,24

0,42

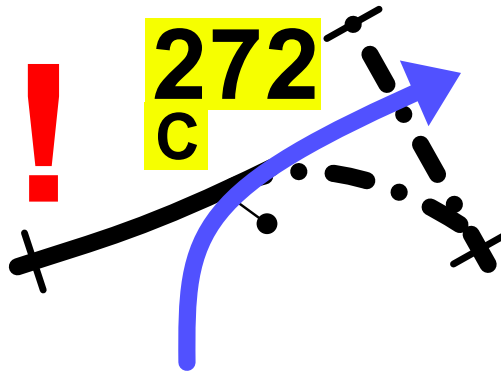

PP 
NBX
CROSS ROAD!

36

102,95

0,71 ↓

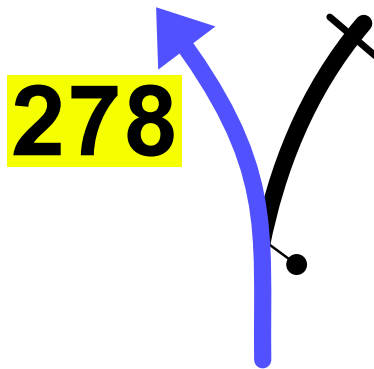

NBX
CROSS ROAD!

103,21

0,26

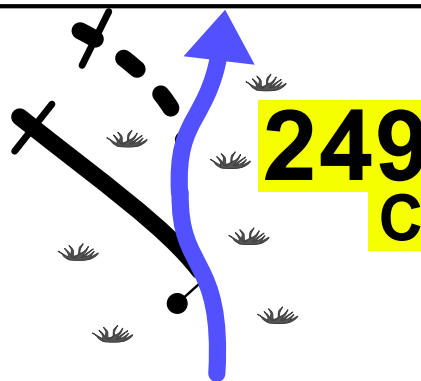

NBX
CROSS ROAD!

Next 0,47

40

RALLY JAMEEL 2024 / DAY 1 Tuesday
SS1 HAIL - AL ULA / 141,56 km

Km : 37,88

103,68

0,47

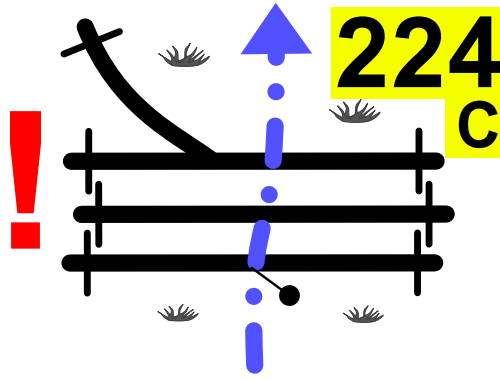

P//

104,23

0,55 ↓ (M)

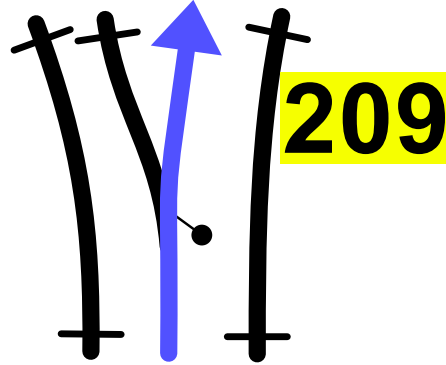

P//

(37)

104,51

0,28

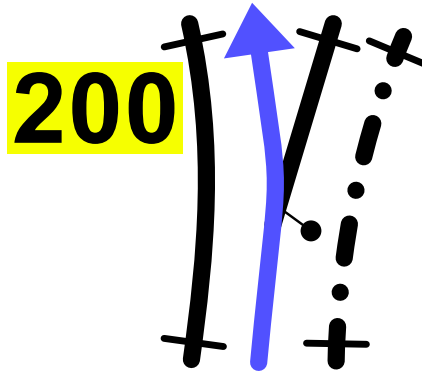

P//

105,74

1,23 (M)

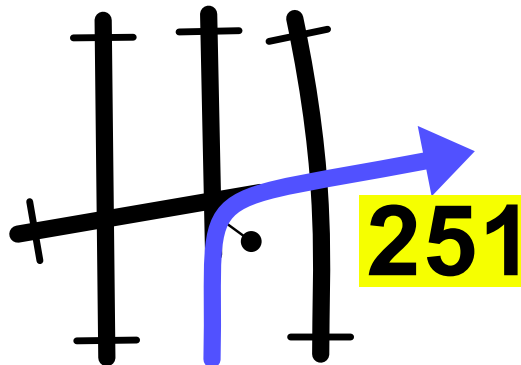

P// S
NBX
CROSS ROAD!

(38)

106,49

0,75 ↓ (M)

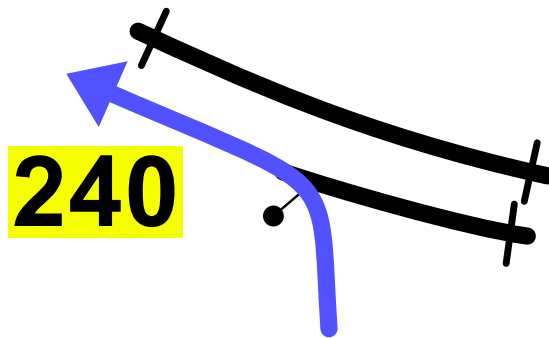

P//

(39)

Next 0,24

41

RALLY JAMEEL 2024 / DAY 1 Tuesday
SS1 HAIL - AL ULA / 141,56 km

Km : 34,83

106,73

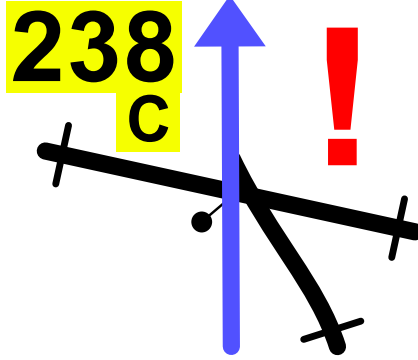

NBX
CROSS ROAD!
PP

0,24

107,63

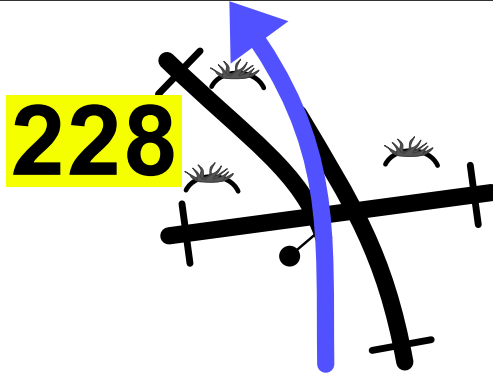

P//

0,90

108,19

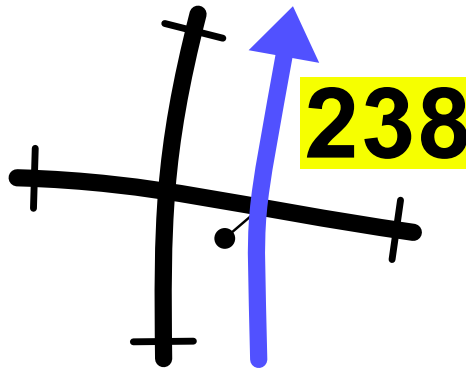

0,56

108,69

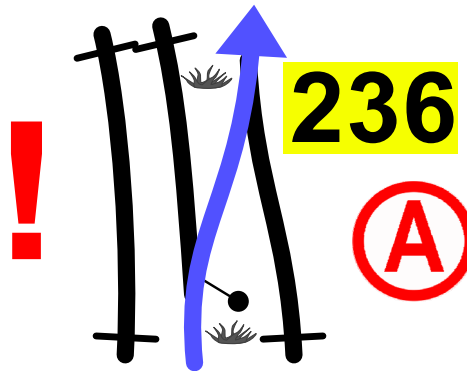

P//

0,50

(M)

(40)

109,80

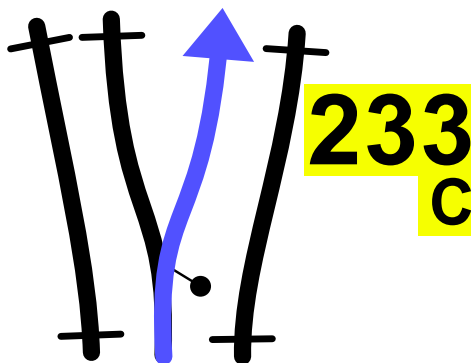

P//

1,11

Next 1,21

42

RALLY JAMEEL 2024 / DAY 1 Tuesday
SS1 HAIL - AL ULA / 141,56 km

Km : 30,55

111,01

240

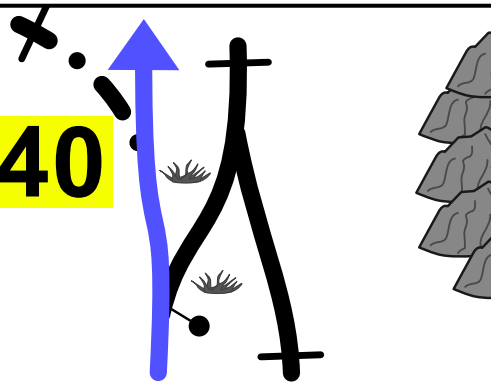

PP P//

1,21

(M)

(41)

111,87

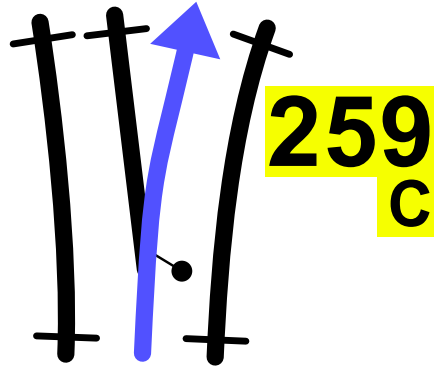

P//

0,86

112,22

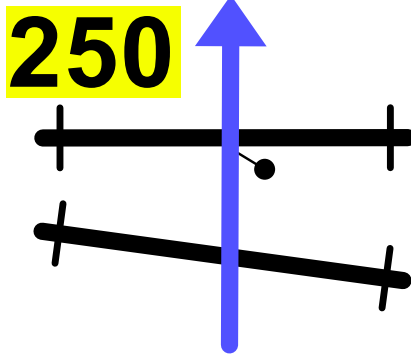

P//

0,35

112,56

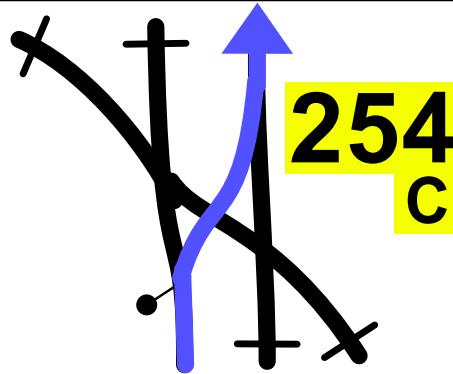

0,34

113,11

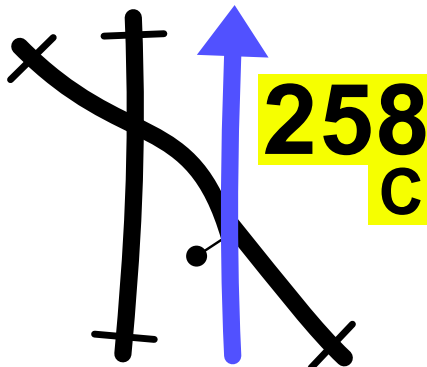

0,55

(M)

(42)

Next 0,38

43

RALLY JAMEEL 2024 / DAY 1 Tuesday
SS1 HAIL - AL ULA / 141,56 km

Km : 28,07

113,49

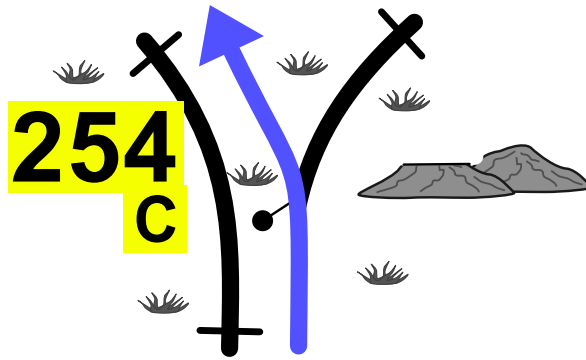

P// PP

0,38

114,10

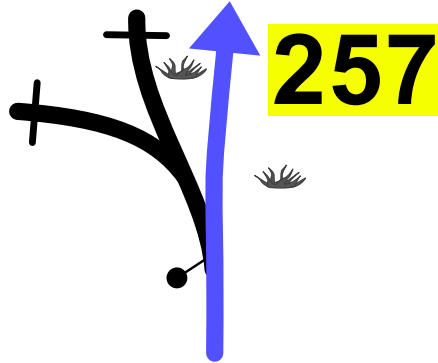

P//

0,61 ↓

114,34

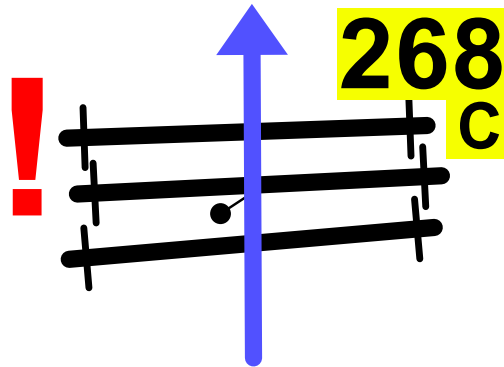

PP 

0,24

M

43

115,46

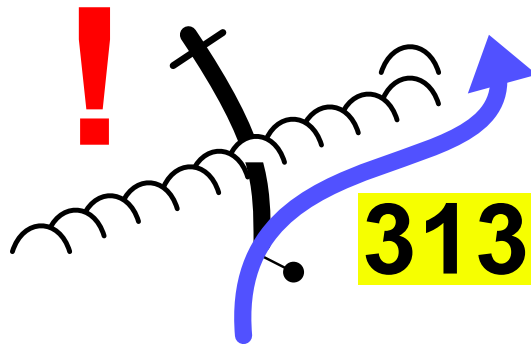

MINE

1,12

OBLIC 256

115,90

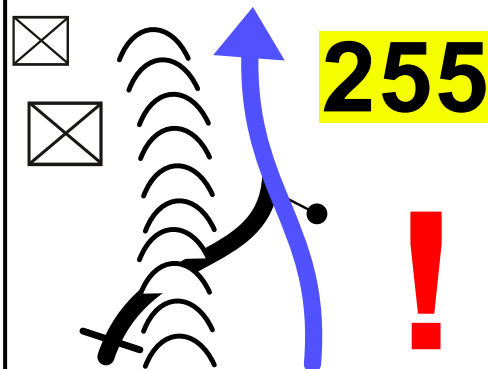

MINE

0,44

P// PP

Next 0,45

44

RALLY JAMEEL 2024 / DAY 1 Tuesday
SS1 HAIL - AL ULA / 141,56 km

Km : 25,21

116,35

0,45

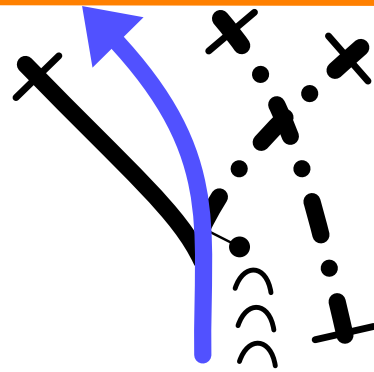

P//



44

116,97

0,62

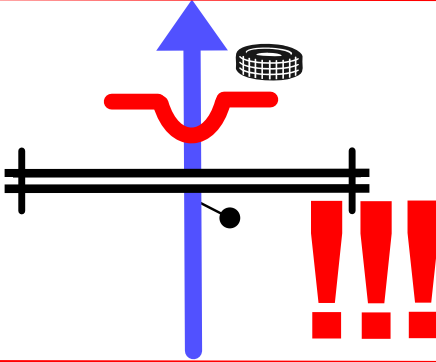

117,20

0,23

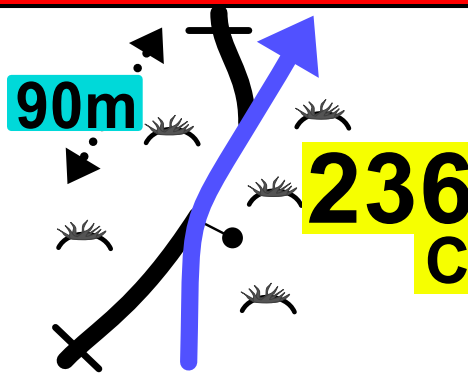

P// PP



45

118,86

1,66

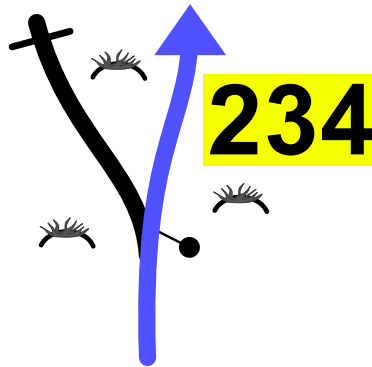

P// PP

119,39

0,53

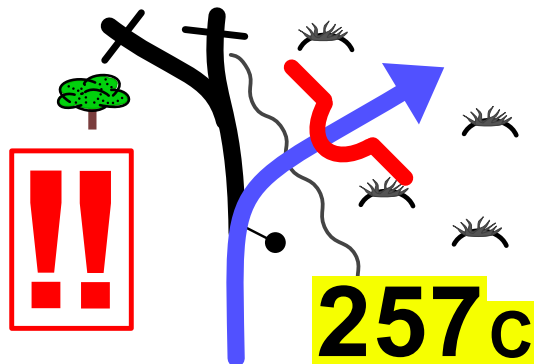

WADI

46

Next 0,43

45

RALLY JAMEEL 2024 / DAY 1 Tuesday
SS1 HAIL - AL ULA / 141,56 km

Km : 21,74

119,82

212

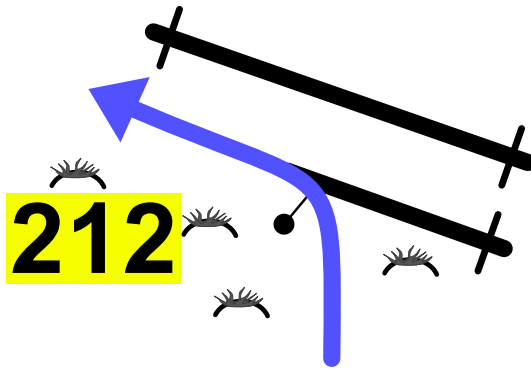

Q^T WADI
P//

47

0,43

M

120,83

211

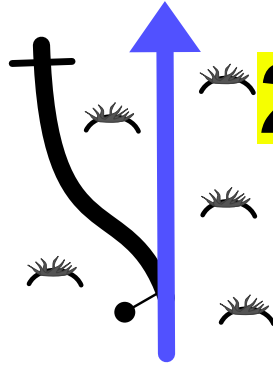

P//

1,01

122,74

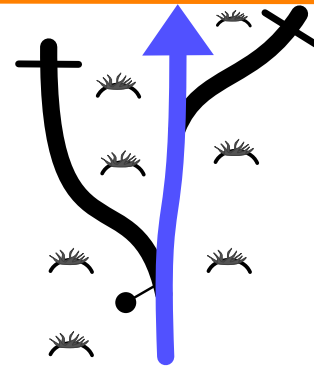

60

48

1,91

DZ

123,21

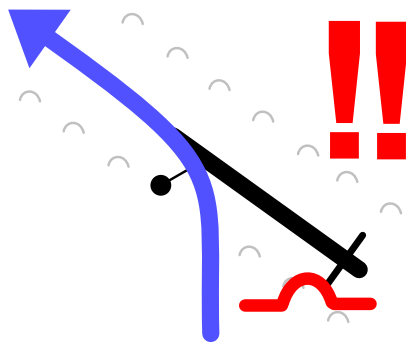

FRO
60

0,47

124,71

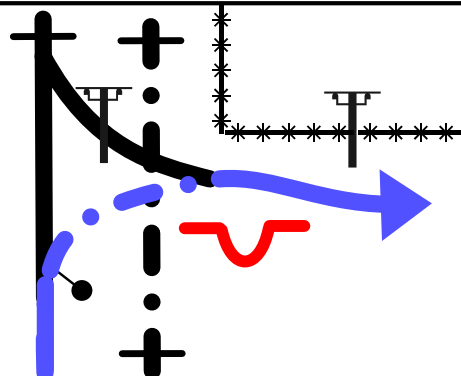

~~60~~

49

1,50

FZ

Next 0,31

46

RALLY JAMEEL 2024 / DAY 1 Tuesday
SS1 HAIL - AL ULA / 141,56 km

Km : 16,54

125,02

0,31 ↓

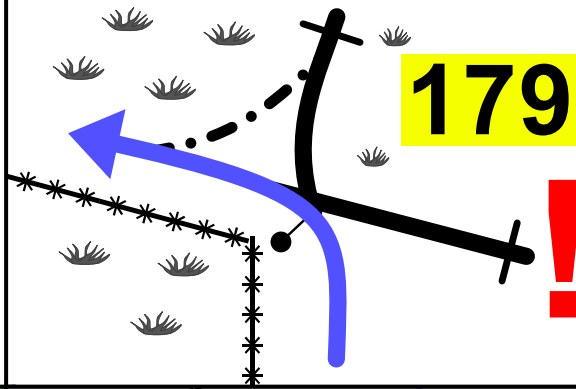

125,30

0,28 ↓

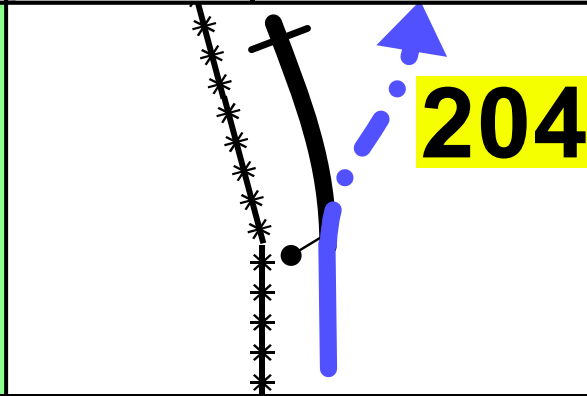

125,45

0,15 (M)

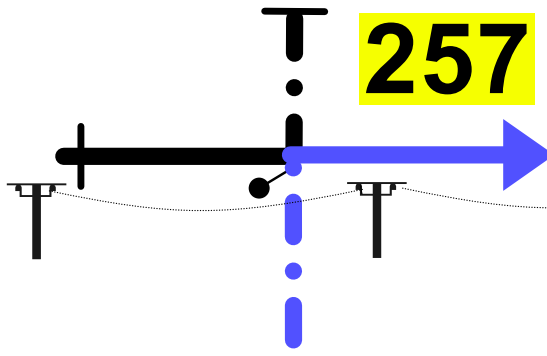

FRO
PP

(50)

128,37

2,92

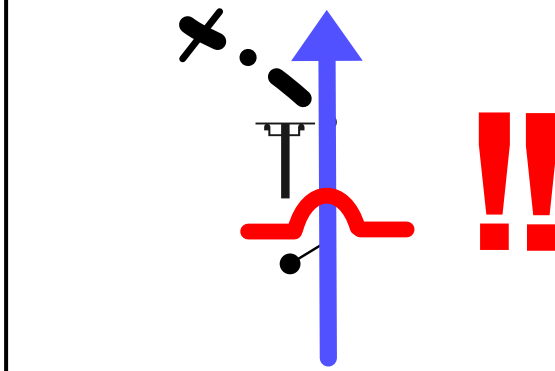

JUMP!

128,74

0,37

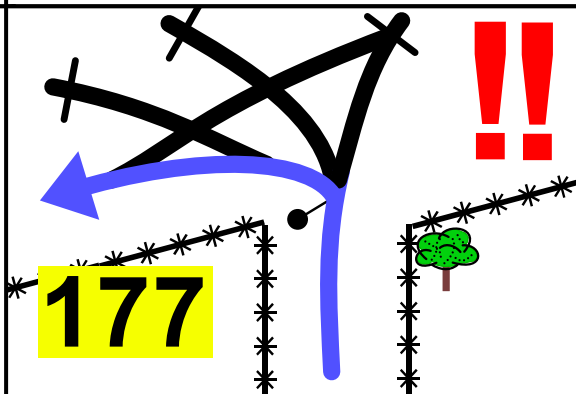

E3
Stones!



Next 0,77

Danger 2

129,51

0,77

(M)

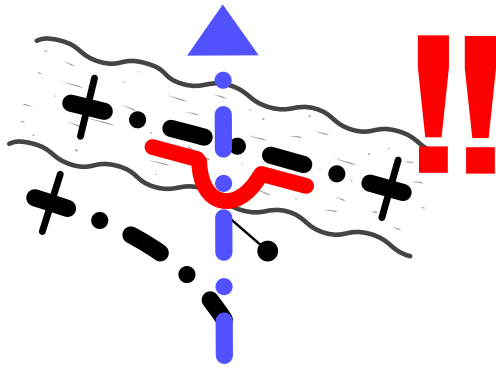

Stones!



(51)

130,14

0,63

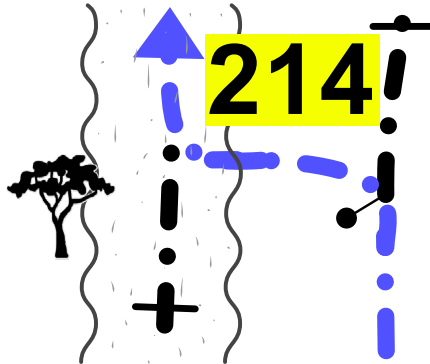

WADI IN!
Stones!

130,66

0,52

(M)



E3

(51.1)

130,99

0,33

(M)

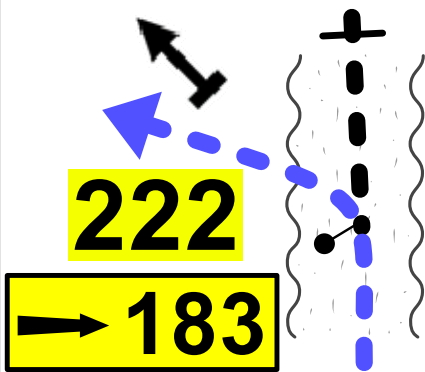

Q^T WADI

Stones!

(52)

131,88

0,89

(M)

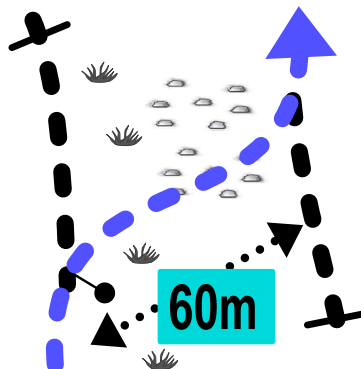

Stones!



(52.1)

48

RALLY JAMEEL 2024 / DAY 1 Tuesday
SS1 HAIL - AL ULA / 141,56 km

Km : 8,82

132,74

0,86

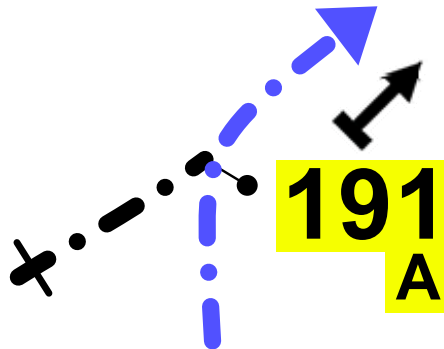

CX

133,16

0,42 ↓ (M)

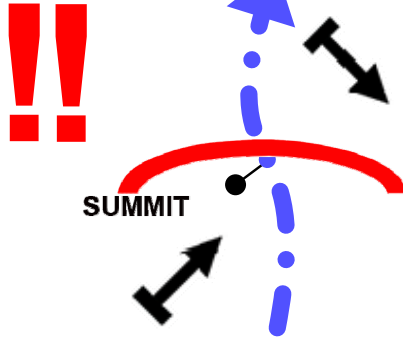

CX S
Stones!

(53)

133,31

0,15

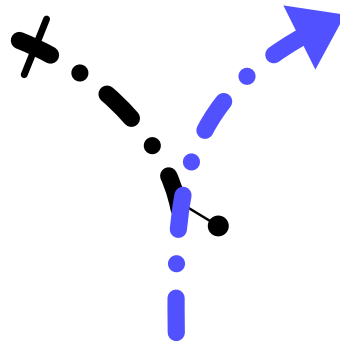

S PP
CX

133,84

0,53 ↓

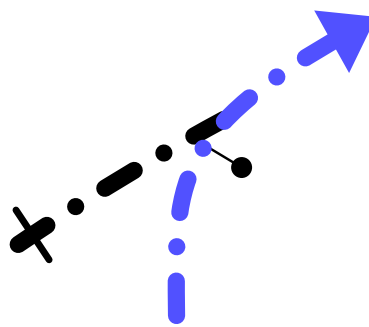

S CX

134,01

0,17

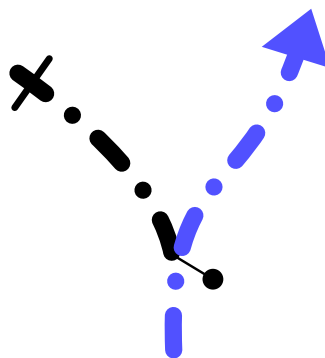

S CX

Next 0,35

49

RALLY JAMEEL 2024 / DAY 1 Tuesday
SS1 HAIL - AL ULA / 141,56 km

Km : 7,20

134,36

0,35 ↓ (M)

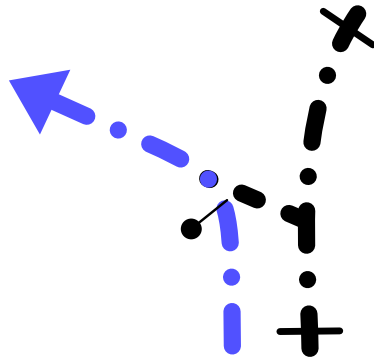

S CX

(54)

134,61

0,25

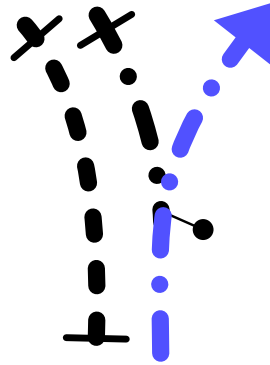

S CX

134,92

0,31

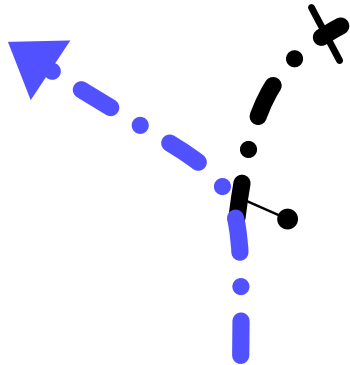

S CX

135,47

0,55 ↓

232

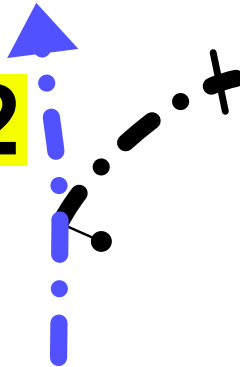

135,62

0,15

(M)

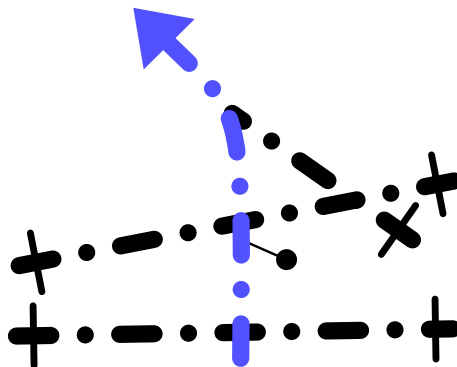

S CX

(55)

Next 0,31

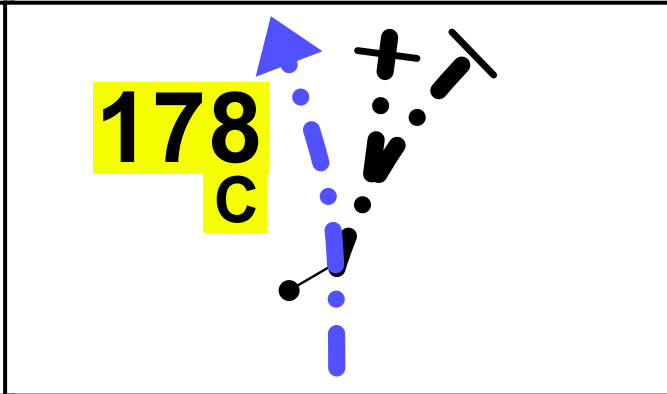
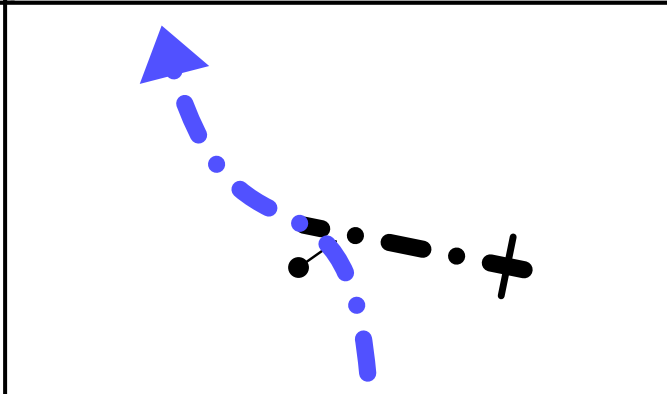
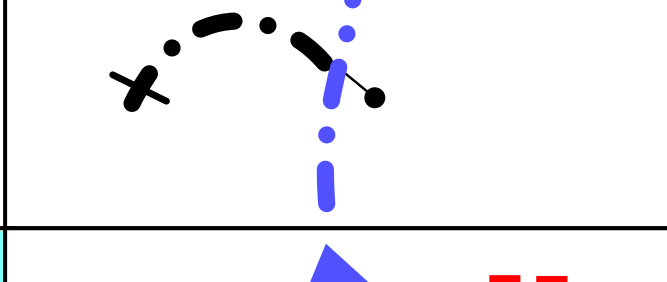
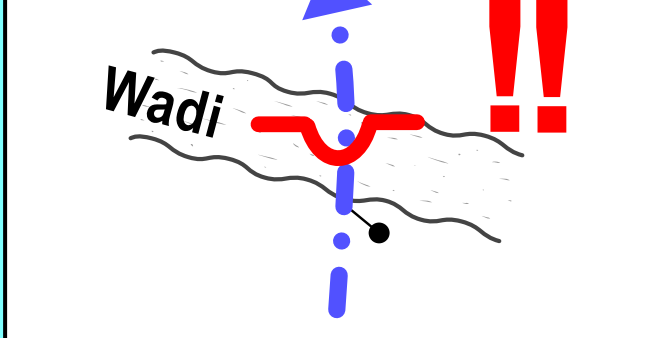
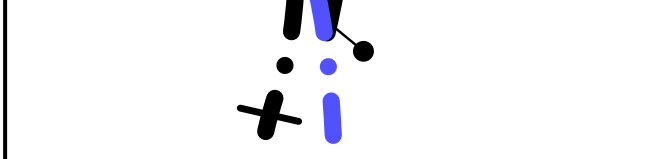
50	RALLY JAMEEL 2024 / DAY 1 Tuesday SS1 HAIL - AL ULA / 141,56 km	Km : 5,63
<p>135,93</p>		<p>S CX</p>
<p>0,31</p>		
<p>136,88</p>		<p>S CX</p>
<p>0,95</p>		
<p>137,50</p>		<p>S CX Stones!</p>
<p><u>137,95</u></p>		<p>S CX PP</p>
<p>0,45</p>	<p>(M)</p>	<p>(56)</p>
<p>138,32</p>		<p>S CX</p>
<p>0,37</p>		

Next 0,49

51

RALLY JAMEEL 2024 / DAY 1 Tuesday
SS1 HAIL - AL ULA / 141,56 km

Km : 2,75

138,81

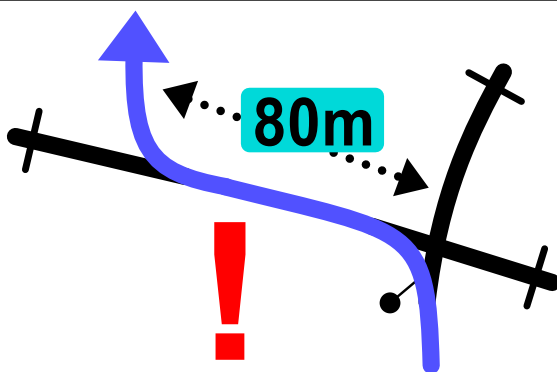

S CX

0,49

139,12

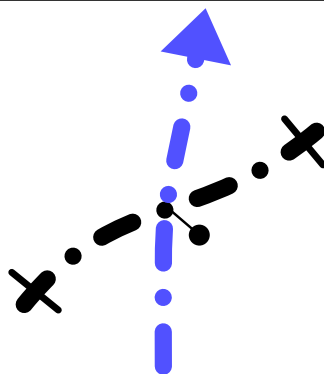

S CX

0,31 ↓

139,34

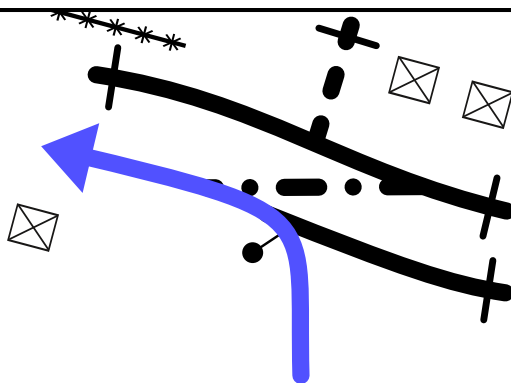

S CX

P//

0,22

(M)

(57)

140,21

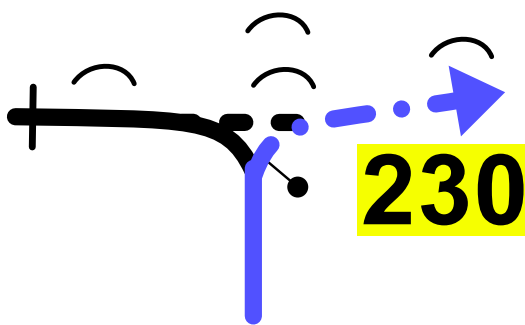

CX

0,87 ↓

(M)

(58)



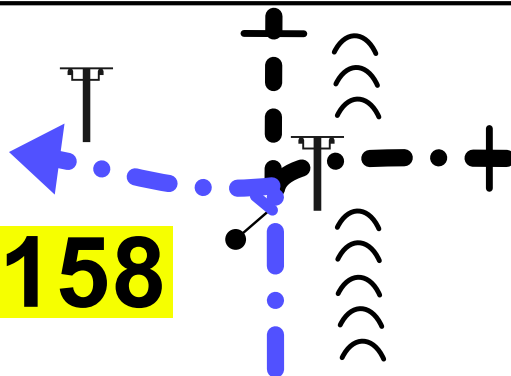



140,37

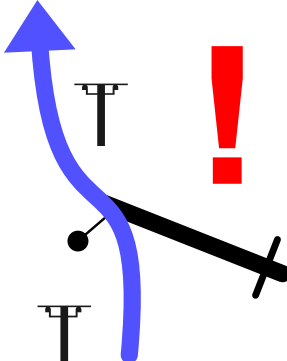
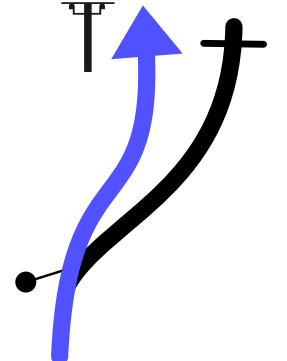
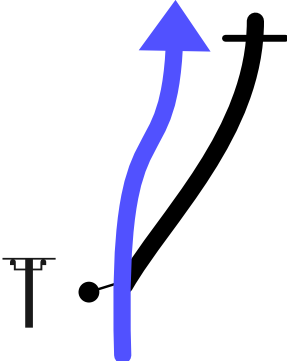
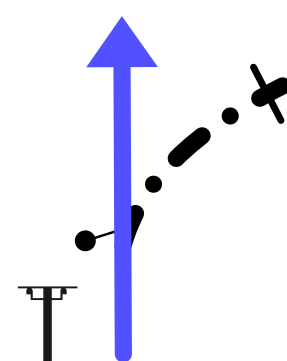

S

0,16

Next 0,86

52	RALLY JAMEEL 2024 / DAY 1 Tuesday SS1 HAIL - AL ULA / 141,56 km	Km : 0,33
141,23		
0,86 ↓		
141,46		
0,23 ↓		 ASS1 HAIL - AL ULA <small>N26°56.167 E40°11.547</small> 
141,56		 SS1 <small>N26°55.958 E40°11.628</small> 
0,10		
141,97		
0,41		

Next

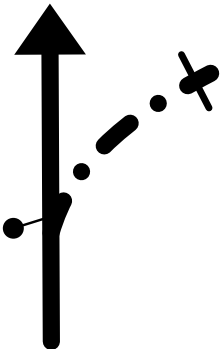
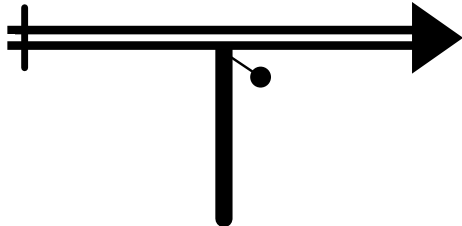
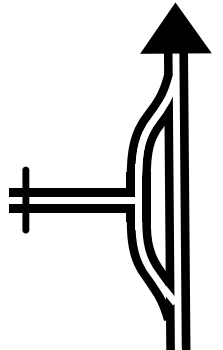
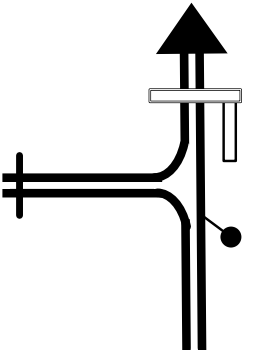
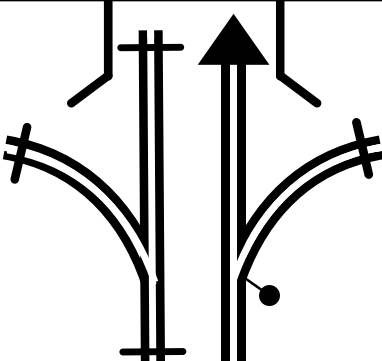
53	RALLY JAMEEL 2024 / DAY 1 Tuesday ROAD SECTION B - AL ULA SERVICE IN / 239,69 km	Km : 239,69
<p>0,00</p>		<p>STOP SS1</p> <p>N26°55.958 E40°11.628 60</p>
<p>0,00 ↓</p>		
<p>0,11</p>		
<p>0,11</p>		
<p>16,49</p>		
<p>16,38</p>		
<p>47,72</p>		<p>CAMERA POINT</p>
<p>31,23</p>		
<p>130,47</p>		<p><u>DIRECTION</u> AL ULA</p>
<p>82,75</p>		

Next 42,45

54

RALLY JAMEEL 2024 / DAY 1 Tuesday
ROAD SECTION B - AL ULA SERVICE IN / 239,69 km

Km : 66,77

172,92

42,45

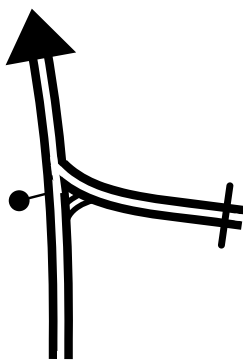

226,70

53,78

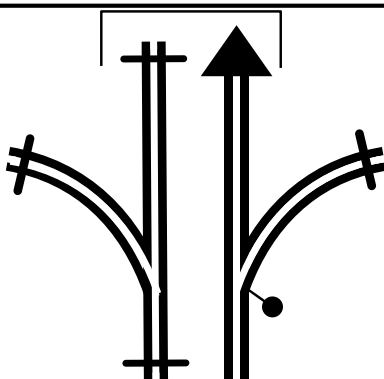

DIRECTION
AL ULA

233,51

6,81

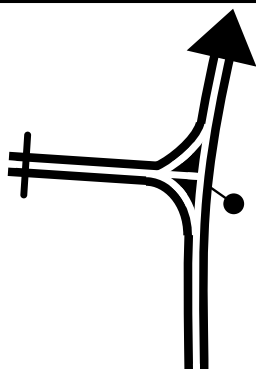

WRONG DIRECTION
~~SAHARY
RESORT~~

235,67

2,16

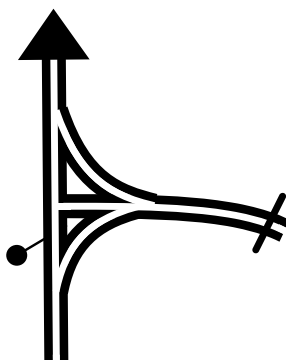



WRONG DIRECTION
~~ELEPHANT
ROCK~~

238,48

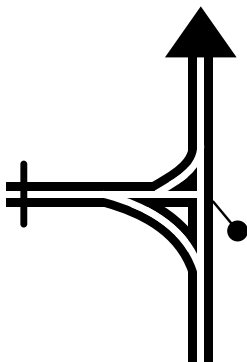
2,81

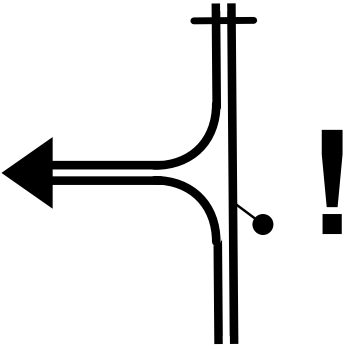
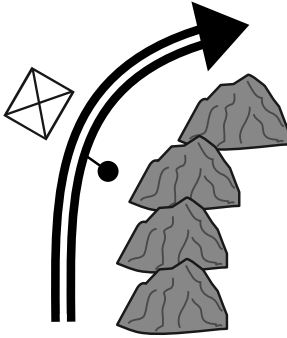
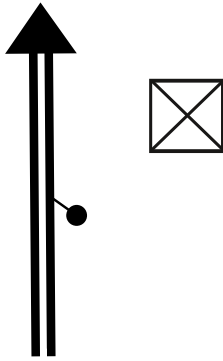

Next 0,42

55	RALLY JAMEEL 2024 / DAY 1 Tuesday ROAD SECTION B - AL ULA SERVICE IN / 239,69 km	Km : 0,79
238,90 0,42		<u><i>DIRECTION</i></u> SHADEN RESORT
239,52 0,62 ↓		SHADEN RESORT IN
239,69 0,17		 TC 1A Al Ula Service In Early arrival permitted <small>N26°39.738 E37°57.746</small>

Next